

IS125 CATALOG

**INDUSTRIAL
SERIES**

Five Day Lead Time

- » Belts marked with the Quick Ship icon (QS) are available with just a five day lead time.



Flat Belt Material Options

- | | | |
|--|---|--|
|  |  | MAA – Multipurpose Belt
Surface: Smooth, White Urethane
Anti-Static: Yes |
|  |  | MAB – Multipurpose Belt
Surface: Smooth, Sealed Edge Urethane
Anti-Static: Yes |
|  |  | MAE – Multipurpose Belt
Surface: Smooth, White Urethane
Anti-Static: Yes |
|  |  | FAA – High Friction Belt
Surface: Snakeskin, Grey PVC
Anti-Static: No |
|  |  | FAF – High Friction Belt
Surface: Rough Top, Green PVC
Anti-Static: No |
|  |  | AAA – Accumulation Belt
Surface: Fabric, Urethane Impregnated
Anti-Static: Yes |
|  |  | AAC – Accumulation Belt
Surface: Fabric, Black Urethane
Anti-Static: Yes |
|  |  | IAF – Cut Resistant Belt
Surface: Dimple Top, Black PVC
Anti-Static: Yes |
|  |  | IAC – Cut Resistant Belt
Surface: Dimple Top, Black Urethane
Anti-Static: Yes |
|  |  | EAB – Static Conductive Belt
Surface: Rough Textured, Nitrile Rubber
Anti-Static: Yes |
|  |  | EAC – Static Conductive Belt
Surface: Smooth, Urethane
Anti-Static: Yes |
|  |  | PAB – Color Contrasting Belt
Surface: Smooth, Urethane
Anti-Static: Yes |
|  |  | PAD – Color Contrasting Belt
Surface: Smooth, Urethane
Anti-Static: Yes |
|  |  | TAA – Translucent Belt
Surface: Textured, Urethane Impregnated
Anti-Static: No |
|  |  | TAB – Translucent Belt
Surface: FDA Fabric Urethane Impregnated
Anti-Static: No |
|  |  | RAE – Release Properties Belt
Surface: Smooth, White Silicone
Anti-Static: No |

More belt options available at qcconfig.com
Consult factory for Heat Resistant and Profile/Specialty Belts

Tail Assembly

- » Snap-in sealed tail assembly offers a best-in-class five minute belt change
- » Crowned for superior belt tracking
- » Thrust washers provide axial float and protect bearings, allowing the assembly to move with the natural camber of the belt

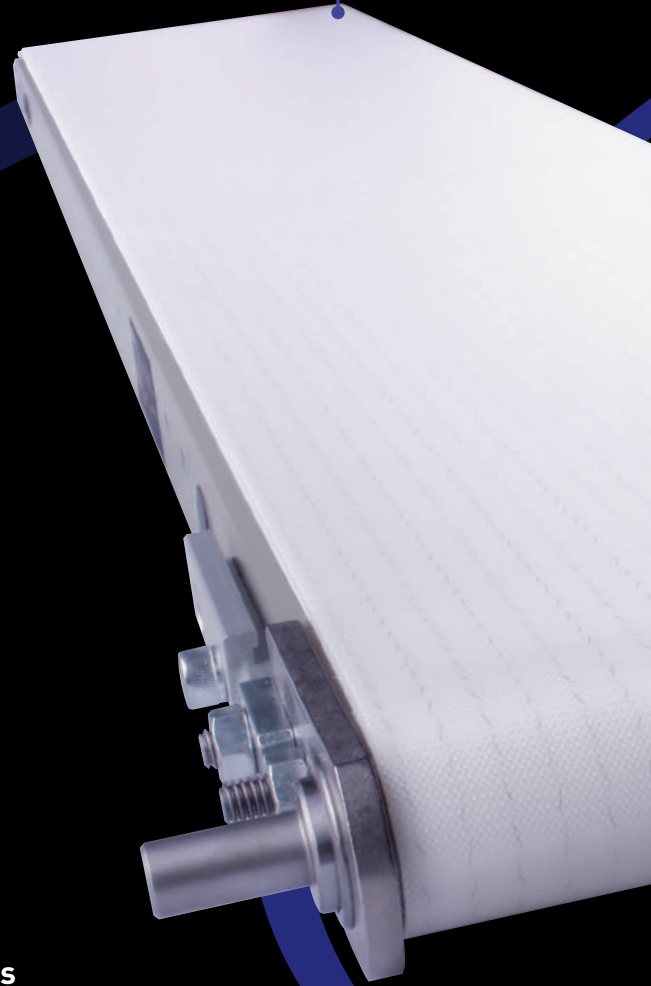

Specifications

- » **Widths:** 2" to 24"
- » **Lengths:** up to 12'*
- » **Profile:** 1.89" high
- » **Load Capacity:** Up to 450 lbs
- » **Speed Range:** Up to 316 FPM

*Extended lengths available through factory consult

Lube-for-Life Bearings

- » Lube-for-Life bearings utilize a **solid lubricant** and eliminate the need for bearing re-lubrication for the life of the bearing
- » Precision rollers offer greater load capacities and longer bearing life



Flat Belt Conveyors

QC Conveyors IS125 Belt Conveyors offer the ultimate in versatility and reliability. With their low 1.89" profile they'll fit almost any application, including tight spaces.

Their steel frame makes them perfect for applications with heavier loads and demanding environments.



Steel Frame

- » Low 1.89" profile design fits tight spaces
- » Laser-cut 10-gauge steel **single-body frame construction** for exceptional frame integrity
- » Powder-coated or stainless steel



Drive Assembly

- » **Straight knurl** design prevents premature belt wear while creating enough friction to provide best-in-class load carrying capacity
- » **Crowned drive pulley** encourages proper belt tracking
- » Thrust washers provide **axial float** to protect bearings against off-center load conditions
- » Single output design is standard; optional dual output available
- » Stand-alone drive assembly guarantees bearing alignment, while allowing the conveyor to be tracked at the drive and tail end

Cleated Conveyors

Cleated conveyors offer positive part movement for lightweight parts and incline/decline applications.

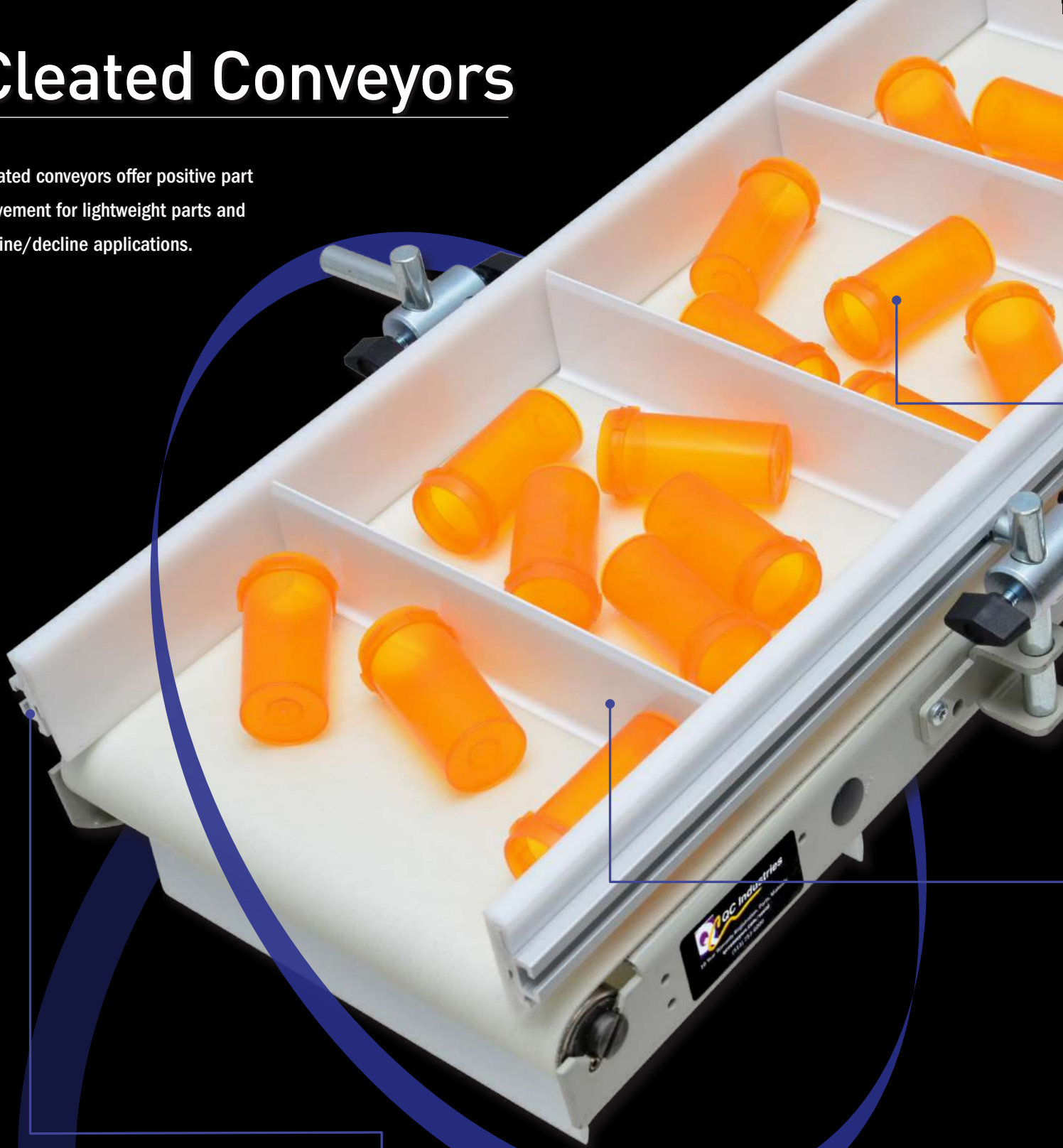

Adjustable Guides and Side Rails

- » Side rails are available in a variety of heights and are highly suggested for product containment on cleated and non-cleated conveyors
- » **Optional adjustable side rails (shown above)** can be adjusted horizontally and vertically; optional thumb screws allow adjustments to be made without tools
- » Sides available with or without wear strips



Product Control

- » Pockets created by cleats and Side Rails keep parts on the belt and moving in positive direction

Durable Cleats

- » Rigid cleats are resistant to bending and warping
- » Cleats are high frequency welded on site, not glued, increasing the strength of the bond between belt and cleat





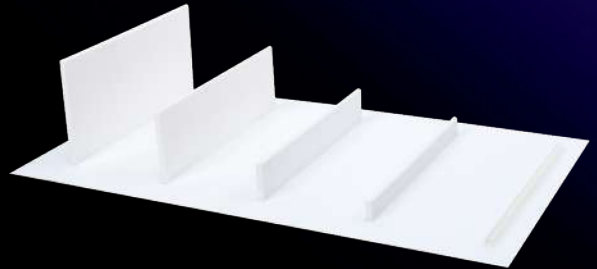

Cleat Choices

A variety of cleat options are available. Use the ordering codes from the chart below when configuring a cleated conveyor.

Cleated belts are intended for use with Adjustable Guides or Indented Guides. Belts have a cleat width of nominal conveyor width minus 1.44". Cleat spacing tolerance may vary; please contact the factory if cleat accuracy is critical.



Height	Code	
5mm	CAB	
1/2 in	CAE	
1 in	CAG	
2 in	CAI	
3 in	CAK	

MAA Belt Material Specifications

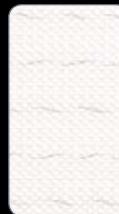

- » MAA is standard for IS125 Cleated Conveyors
- » Surface: Smooth Urethane
- » FDA: Yes
- » Ambient Temp Range: -22 to 176°F
- » Part Temp (Short Term): -22 to 176°F
- » Thickness (approx): 1.5mm (.06")

Seven Day Lead Time

- » Cleated MAA belts are available with at 7 day lead time



Flextrac Plastic Chain Conveyors

Flextrac plastic chain conveyors are available with a variety of options. Plastic chain allows for heavier loads, higher speeds, and longer conveyors, while maintaining the versatility and reliability expected from our IS125 conveyors.

Steel Frame

- » Laser-cut 10-gauge steel **single-body frame construction** for exceptional frame integrity
- » **Powder-coated or stainless steel**
- » Plastic wear strips allow for smooth, quiet belt movement and continuous belt tracking
- » **Three standard wear strip options:** edge guides do not extend above the belt height (shown), 1" sides extend above the belt height by .5", and 2" sides extend above the belt height by 1.5"



Drive Assembly and Sprocket

- » Plastic chain conveyors have a unique sprocket drive assembly
- » Sprocket allows for heavier loads, non-slip belt movement, consistent belt tracking, and higher speeds



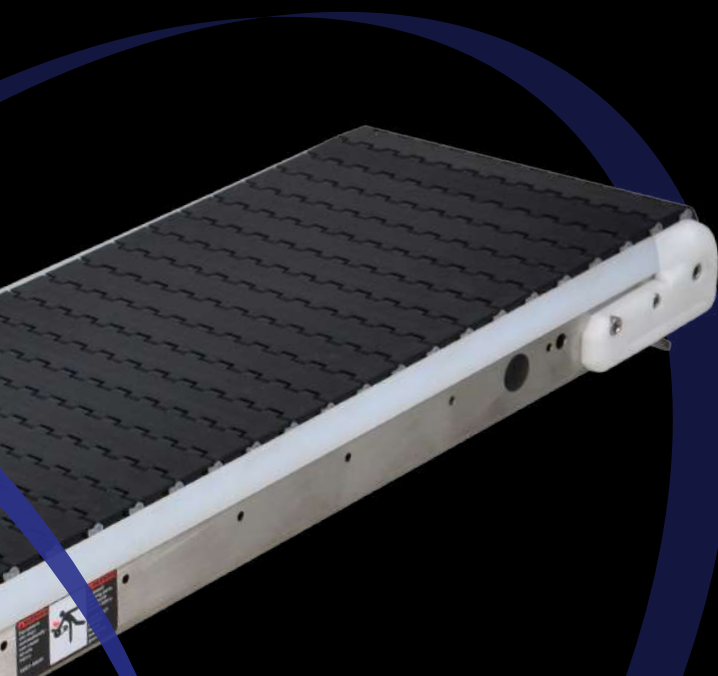

Specifications

- » Widths: 4" to 24"
- » Lengths: up to 40'
- » Profile: Drive End: 3.01"; Frame: 2.41"
 - » Load Capacity: Up to 500 lbs
 - » Speed Range: Up to 375 FPM

Catenary Sag Unit



For conveyors over 20' in length a Catenary Sag Unit will be attached to the frame, behind the drive. This unit adds 7.5" to the profile of the conveyor at the drive end.

Lube-for-Life Bearings



- » Lube-for-Life bearings utilize a **solid lubricant** and eliminate the need for bearing re-lubrication for the life of the bearing
- » Precision rollers offer greater load capacities and longer bearing life

Plastic Chain Belt Options

Each Flextrac option is a 1" pitch modular belt, so each chain module is 1" wide. The modules are linked with plastic pins to create the belt. The options listed below are available in a variety of plastics including FDA, antistatic, chemical resistant, and high temperature resistant.

Flush Grid Belt Materials

General purpose plastic chain best suited for general conveying, cooling and draining, and food applications.

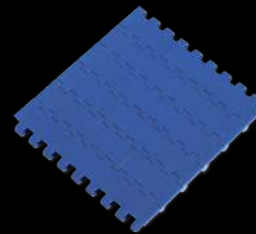
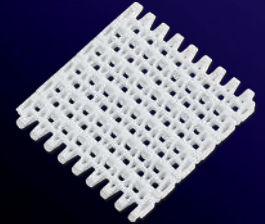

Flat Top Belt Materials

Flat top belts have a 0% open area and high lateral stiffness.

Grip Top Belts

Grip top belts are an abrasion resistant, high friction belt option.

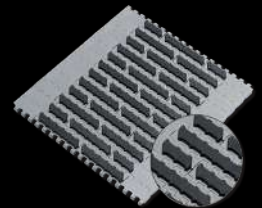

Flights

Single piece, injection molded flights can be assembled into the belt. Flights keep product moving in a positive direction in incline applications, and prevent product from falling too quickly in a decline application. They can also be used in tandem with side guards to make a pocket for moderately sized parts.

Available heights are 1", 2" and 3".



Side Guards

Standard side guards are fastened into the belt at the edges to prevent parts from falling off the sides of the belt. They are available in a 2" height.

24/7 Online Quoting

Configure and quote conveyors 24 hours a day using our online Conveyor Configurator. An intelligent assistant uses engineer-developed rules to make sure all your components – including gearmotors, stands, and sides/guides – work together properly.

Conveyor Configurator

Fast, intelligent online configuration and quoting

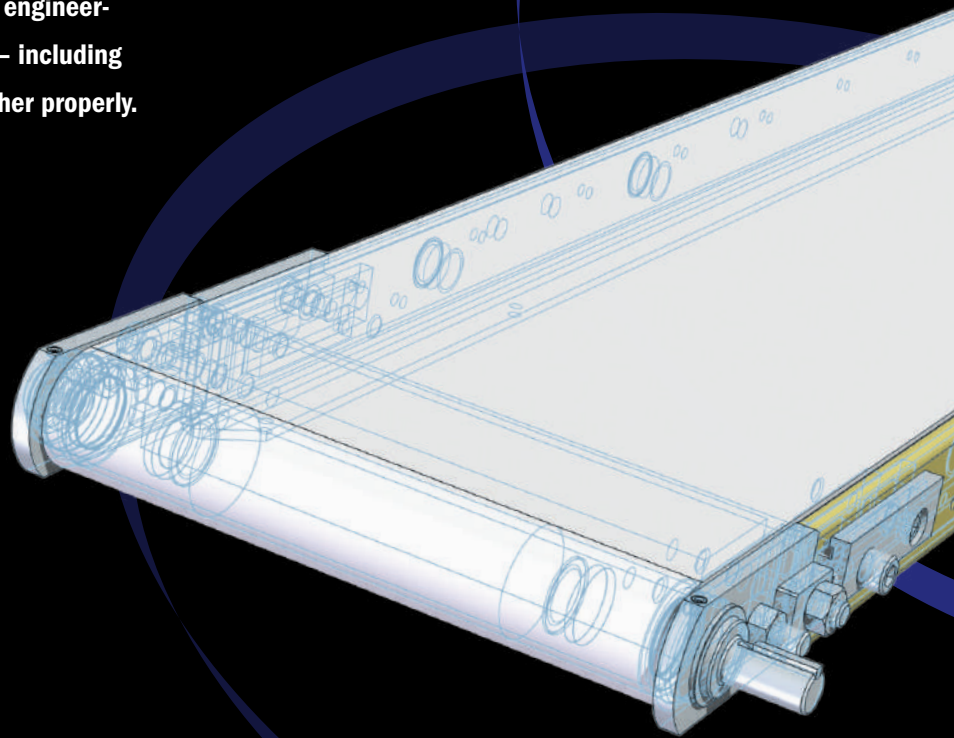

Fast, Intelligent, Online

- » Manage multiple conveyors in a single quote using separate bills of materials
- » Our algorithms identify errors and offer options for making corrections
- » Register your conveyor to qualify for our 10 Year Warranty
- » Access appropriate manuals and videos by serial number to make maintenance easy
- » View past orders and quote replacement parts directly from the original bills of materials, complete with exploded views to help you find exactly the right part

Download 3D CAD Models

Once you've designed a conveyor with the *Conveyor Configurator*, you can download all the 3D CAD models, exploded views and specifications in one package to make integration with your application easy. We've included sides/guides, drives, stands and automation accessories, so it's easy to drop the complete conveyor system directly into your application.



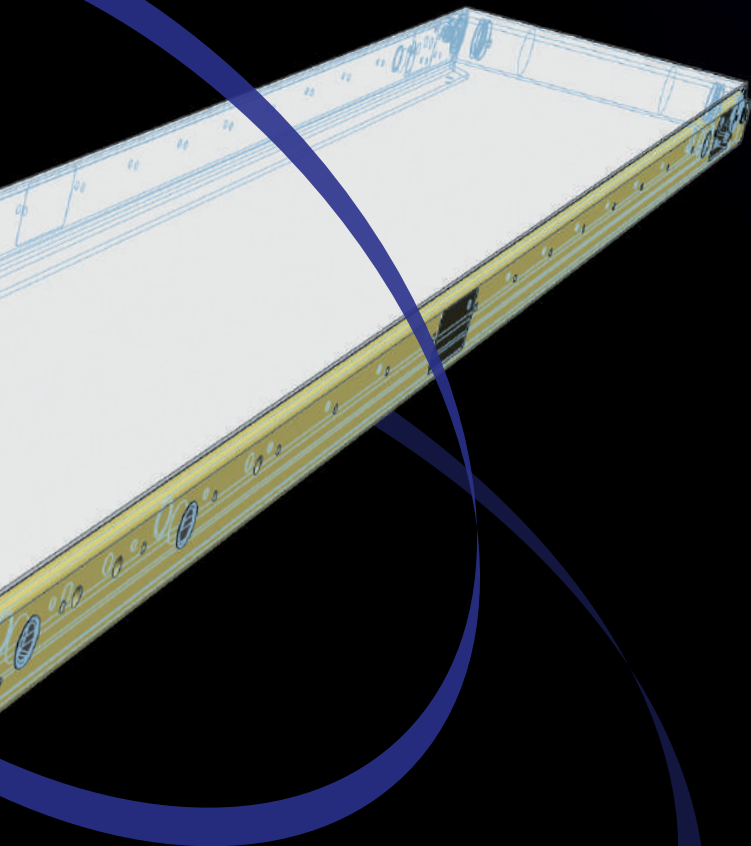

10 Year Limited Warranty

Our products are developed and tested with long-term reliability in mind. To ensure our conveyors will run problem-free in the field for many years, we demand the tightest tolerances in the industry and manufacture our components using the most advanced processes available. Each conveyor is inspected at several points of the manufacturing process to ensure quality, including a final operational test before it leaves our facility. That's why we confidently stand behind our products with a 10 year warranty when they're registered at qcconveyors.com/serial.



5 Day Lead Times

Many of our most popular conveyors are available with just a five day lead time. Several of our most popular belt options are available for quick shipment. Look for the Quick Ship icon in our Conveyor Configurator to guide your selections and ensure a five day lead time!



Why QC Conveyors?



For more than 35 years, we've been focused on one thing: providing our customers with reliable, easy to use conveyor systems that meet their needs, then backing them with world class service and support. Whether you're an end user looking to decrease your line's downtime or an OEM putting our conveyor in a machine with your company's name on it, QC Conveyors offers the quality, reliable product you're looking for.

We view our customers as partners, not for a single sale but for the long run. We regularly meet with them to learn how our products can better meet their needs and work hard to incorporate those needs into our products. In addition, we have a dedicated team of customer service professionals ready to assist in any way they can, each empowered with the flexibility to keep customers happy.



We invite you to visit our state of the art headquarters in Cincinnati, Ohio, where you can get your hands on our product and see first hand how easy it is to use and maintain. Once you do, we're confident you'll be a customer for life.

Gearmotor Mounting Packages

Side Drives

Side drive mounting sets the gearmotor to either side of the conveyor. Can be used with any of our gearmotors.



Bottom Drives

Bottom drive mounting sets the gearmotor **below** the conveyor. These drives may be affixed to either side of the conveyor. Available with either a timing belt or chain. Can be used with any of our gearmotors.



Top Drives

Top drive mounting sets the gearmotor **above** the conveyor. These drives may be affixed to either side of the conveyor. Available with either a timing belt or chain. Can be used with any of our gearmotors.



Gearmotors

Standard Duty Fixed Speed Gearmotors

Specifications/Features

- » Available in 40 Watt, 90 Watt and 200 Watt
- » 115V & 230V Single Phase, and 230V Three Phase
- » 40 Watt Variable Speed Electric Gearmotor available with housed controller attached alongside the gearmotor
- » NEMA 4X controller can be used to achieve variable speed capabilities



Heavy Duty Fixed and Variable Speed Gearmotors

Specifications/Features

- » Available in 115V & 230V Single Phase, 230V & 460V Three Phase, and 90V DC
- » Optional Controllers available for both AC and DC Heavy Duty Gearmotors



Brushless DC Gearmotor & Control

With its integrated DC controller, the Brushless DC gearmotor offers the greatest range of speed adjustment of any of our gearmotors. The controller features a built-in speed potentiometer to allow for easy adjustment, or it can be set for specific speeds. It also integrates with outside control systems for automated operation. A 3m (10 ft) cable is included for connecting to the gearmotor.

Control Specifications/Features:

- » 50:1 speed range
- » UL/ULc/CE
- » IP20 Protection Rating
- » Three speed display modes
- » Multi-speed operation using up to eight different speeds

Gearmotor Specifications/Features

- » Available in 120, 200, and 400 Watt
- » Available for 115V Single Phase, 230V Single Phase, and 230V Three Phase.
- » Variable Speeds: 1- 225 FPM

Note: 400 Watt Gearmotor is only available in 230V Three Phase.



To find gearmotor and mounting package part numbers, please visit the Conveyor Configurator – qccconfig.com.

Note: It is the responsibility of the end user to properly wire controllers and gearmotor starters to the gearmotor.

Guides, Side Rails & Dividers

GUIDES, SIDE RAILS & DIVIDERS

2-Axis Adjustable Guides



Adjustable side rails offer the ultimate in flexibility. These guides may be adjusted vertically for varying product heights or horizontally to create full width or indented guides. These guides are available with optional thumb screws (shown) for tool-less adjustments.

Fixed Side Rails



Side rails can be used to contain and guide product on the conveyor. They are available in 1/3", 1" (shown) and 2". You may also order them with seals to keep product or contaminants from slipping under the belt or with a wear strip to protect the sides and product from scuffs and marks.

Not compatible with all belt choices. See qcconfig.com for more information.

Flared Side Rails

Flared side rails attach to adjustable side rails to guide falling products to the conveyor. They are traditionally used with cleated conveyors for product control. End stops may also be used to prevent product from falling from the tail section of the conveyor. A swing gate attached to the end stop aids in guiding product and accommodates cleats up to 2" in height.



Lane Dividers

Lane dividers are ideal for separating products as they move down the conveyor. Rail clearance options are 2" or 3" (shown), and the dividers may be either frame mounted or t-slot mounted. Available with thumb screws for tool-less adjustments.



QC CONVEYORS
QCCONVEYORS.COM

Aluminum Stands

Aluminum stands are our most popular support option. They offer adjustability in an economical package.

No additional mounts are required. Note: Conveyors 4" wide and under will have the stand framework on the outside of the conveyor. The minimum height range for these conveyors is 12-15 inches.

Cross Ties

Cross ties increase the stability of the stands. It is suggested that a set of cross ties is ordered for every 12' of conveyor.

Note: Aluminum stands sold separately.

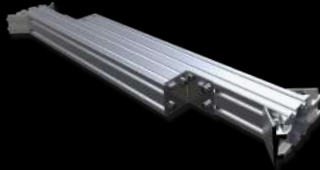

Outrigger Stands

The Aluminum Outrigger Stand offers a wider base for enhanced stability, especially for narrow conveyors.

Note: No additional mounts are required.



Angle Braces



For use with aluminum stands.

Note: When used with casters, angle braces must be used on both stands. Angle brace cannot be used on inclines or declines.

Casters



Order two per stand.

Swivel locking casters increase stand height by 5.50". Casters should only be used with stands that are 1/3 as wide as they are tall.

Drop In Tee Nuts



Can be inserted into Tee Slots on conveyor stands. M6 thread.

Note: There is a 3" overall height adjustment with feet. All applications will require the end user to properly lag stands and ensure stability. Because every application and installation is different, the functionality and performance of the supports depend on the end user. QC Conveyors can aid in determining the supports your application requires.

Mounts & Accessories

Universal Adjustable Side Mount

Frame Mounted version attaches directly to the frame with mounting holes every 3" (compatible with cleats 1" or lower). T-slot mounted version attaches to 1" Side Rails, 2" Side Rails, the Single T-slot and the Multi T-slot (compatible with cleats 1/2" or lower).



Universal Raised Side Mount

Frame Mounted version attaches directly to the frame with mounting holes every 3". T-slot mounted version attaches to 1" Side Rails, 2" Side Rails, the Single T-slot and the Multi T-slot. Brackets are universal and work on either side of conveyor. Compatible with any standard cleat height.



Tee Mount

Attaches directly to the conveyor frame. The frame has mounting holes every 3". Brackets are universal and can work on either side of the conveyor. Cannot be used with cleated belts.



Drip Pans

Drip Pans are ideal for recapturing oils and lubricants. They include 1/2" drain holes at both ends. Designed for use with fixed side rails with clamps and the Universal Adjustable Side Mount only.



Adjustable Stops

Adjustable stops are available for 1" Sides, 2" Sides and the Single T-slot (1" tall).



90° Transfer Plate

The 90° Transfer Plate covers the gap between perpendicular conveyors, easing product transfer. They are not intended for high friction or cleated belts. The discharge conveyor must be pushing. The customer must drill screw holes to mount plate.

Not available with Flextrac conveyors.



Adjustable Diverters

The adjustable diverter includes a 5' piece of UHMW rail and 2 mounting assemblies that the user can utilize to help orient the product around a 90° transfer.

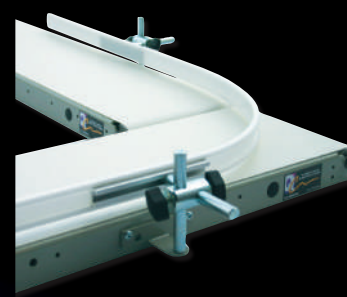

Custom Conveyor Solutions

If you're looking for something a little different than our standard conveyors, we can customize it for you. Whether it's a bracket to integrate with a customized piece of equipment, a drive mount for your gearmotor, or a modification to one of our conveyors to fit your application parameters — give us a call. Below are a few custom solutions we have created.

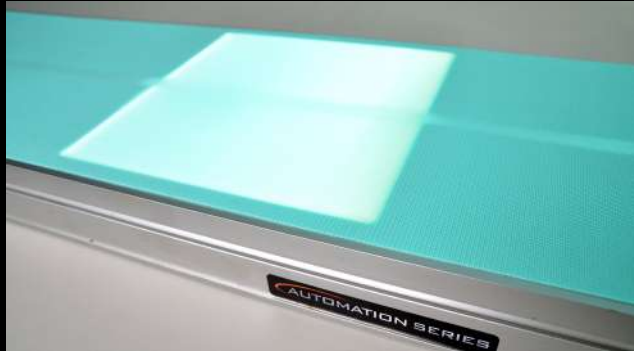

Backlighting

Our conveyors can be modified to accept a wide variety of customer-specified backlights for vision applications. When coupled with a translucent belt, the conveyor creates an ideal platform for inspection as parts travel past.



Custom Stands & Side Tables

We're often asked to design special stands to accommodate each customer's unique requirements. In this pack-off line, candy came in from the wrapping machines and was packed by hand into boxes coming in from the box erector. The filled boxes then left on a third line of conveyors for shrink wrapping. The application required custom stands and stainless steel side tables where operators packed the boxes.



Multiple Bands

In this application, our customer needed to perform an operation on the bottom of a part as it moved across the conveyor. Our solution involved running two belts on the conveyor with a cutout between them. The part straddled the two belts and a robot performed the operation from below through the cutout.



Elevator Conveyors

For an application that required product to move across a healthcare packaging plant, we devised an elevator system to elevate the bins to move overhead across the plant. The system consisted of two 300 Series Indexing Conveyors with an InnerDrive Conveyor mounted between them. After bins moved onto the InnerDrive conveyor, the 300 Series conveyors moved in tandem to raise the InnerDrive conveyor, which then moved the bins onto the overhead conveyor system.

Learn More

Additional Products Available from QC Conveyors

In addition to our versatile IS125 conveyors, we offer a variety of other products. Other options in our **Industrial Series** include IS175-ID conveyors with an embedded drive, and IS300 conveyors which feature a timing belt with accuracy to ± 0.15 ". **Automation Series** conveyors are built on a rigid aluminum frame, and **HydroClean Series** conveyors are built on a stainless steel platform with a design that makes them easy to clean. Please visit our website or contact your local distributor for more information.



qcconveyors.com

QC Conveyors' website — qcconveyors.com — is your resource for the most up-to-date information about all of our products.



Conveyor Configurator

Configure & quote conveyors online, 24 hours a day. See page 8 for more information.



Your Local Distributor

Contact our sales department today at (513) 753-6000 to find your local distributor.



ACAT MEXICANA S.A. DE C.V.

Avenida Regio Parque #200, Regio Parque Industrial, Apodaca N.L. C.P. 66633



www.acatmexicana.com



acat@acatmexicana.com



TEL. 81 8354 8910



(513) 753-6000 | qcconveyors.com | Part # MKTG-IS125-0119



THE DURAVANT FAMILY OF COMPANIES

www.duravant.com

ARPAK | FISCHBEIN INTERNATIONAL | FMH CONVEYORS | HAMER-FISCHBEIN | KEY TECHNOLOGY | MARLEN INTERNATIONAL | MESPACK | OHLSON | QC CONVEYORS