

PROUD AMERICAN MANUFACTURER

ACAT

TEL. 81 8354 8910
www.acatmexicana.com

Scotchman™

Metal Fabricating Solutions

Ironworkers | Cold Saws | Automatic Sawing Systems | Hydraulic Press | Pipe Notchers | Measuring Devices

Cold Saws

COLD SAWS



Manual to Fully Automatic Circular Cold Saws For Ferrous & Non-Ferrous Materials

A Circular Cold Cut Saw is the best machine for cutting ferrous and non-ferrous metals. For mild steel and other ferrous materials, this unique type of cutting turns the blade at a very low RPM, similar to a milling process, giving a FAST, precise, burr-free cut without heat or sparks.

The Scotchman Cold Saw line is complete with both ferrous and non-ferrous models, manual to fully automatic, and is capable of cutting straight or angled cuts.

Scotchman also offers a complete selection of cold saw blades in stock for immediate delivery. Our in-house blade sharpening service provides high-quality and consistent results with a quick turnaround time.

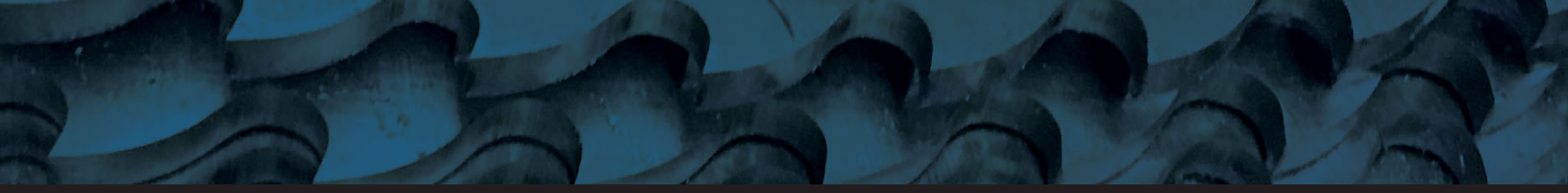

COLD SAWS

MANUAL TO SEMI-AUTOMATIC

CPO 350 SERIES
PIVOT STYLE SAW29-30

CPO 275 SERIES
PIVOT STYLE SAW 31

OPTIONS AND ACCESSORIES
FOR CPO 350 & 275 32

AUTOMATIC

HITCH FEED AUTOMATIC (HFA)
PIVOT STYLE 90° SAW33-34

ROLLER FEED AUTOMATIC (RFA)
PIVOT STYLE 90° SAW 35

AUTOLOADER
PIVOT STYLE AUTOMATIC SAW 36

SUP SERIES - (500 & 600)
UPCUT STYLE MITER SAW37-38

GAA SERIES - (500 & 600)
UPCUT STYLE 90° SAW39-40

SAW BLADES, OPTIONAL EQUIPMENT & SERVICES ..41-42

Cold Saws *CPO 350 Series*

Steel & Ferrous metal cutting

COLD SAWS

CPO 350

MANUAL SAW

- Manual clamp for material vise
- Operator controlled trigger switch



CPO 350 PK

MANUAL SAW W/POWER CLAMP

- Air-operated clamp for material vise
- Operator controlled trigger switch



CPO 350 PKPD

SEMI-AUTOMATIC SAW

- Air-operated clamp for material vise
- Pneumatic power down feed with electric controls
- Emergency stop button



STANDARD FEATURES

- Double self-centering vise assures burr-free cuts
- Miter capabilities 45° left to 45° right
- Miter locking device: quick, accurate setting-stops at 45° left, 90° & 45° right
- Capable of slotting
- Two cutting speeds
- Double reduction, hardened bronze gears
- Chip drawer
- Seven-gallon flood coolant tank with pump
- One HSS blade
- One gallon coolant
- Complies with ANSI B 11.10 safety standards
- Three-year warranty on parts
- Made in USA

MAXIMUM CAPACITIES

(with a 350 mm blade)

tubing	90 Degree	45 Degree
Round	4-1/2" (114 mm)	4" (102 mm)
Square	4-1/4" x 4-1/4" (108 x 108 mm)	3-3/4" x 3-3/4" (95 x 95 mm)
Rectangle	5-1/2" x 4" (140 x 102 mm)	3-3/4" x 3-3/4" (95 x 95 mm)
Solid	90 Degree	45 Degree
Round	1-3/4" (44 mm)	1-1/2" (38 mm)
Square	1-3/4" x 1-3/4" (44 x 44 mm)	1-1/2" x 1-1/2" (38 x 38 mm)

SPECIFICATIONS

Motor Options (must specify)	LT & HT- 208/230/460/575v, 3ph; 220v, 1ph VS- 230/460v, 3ph; 220v, 1ph SS- 220v, 1ph
Air Pressure	90 psi (PK and PKPD. N/A on CPO 350)
Maximum Diameter Blade	350 mm
Arbor Bore	40 mm
Pin Spacing	4/12/64
Width	21-7/8" (55.5 cm)
Depth	43-1/2" (110.5 cm)
Height (not incl. feed handle)	56-1/4" (143 cm)
Height (floor to vise)	37-7/16" (95 cm)
Shipping Weight (may vary)	CPO 350 660 lbs. (299 kg) CPO 350 PK: 690 lbs. (313 kg) CPO 350 PKPD: 760 lbs. (345 kg)

CUTTING SPEEDS (must specify)

LT (Low Turn) designed for solid mild & stainless steel, & thick wall pipe.	LT 22/44 rpm, 3hp (2.24 kW)
HT (High Turn) designed for thin wall tube 0.060 wall thickness or thinner and non-ferrous material	HT 44/88 rpm , 3hp (2.24 kW)
VS (Variable Speed)	VS 11 to 177 rpm, 5hp (3.73 kW)
SS (Single Speed)	SS 44 rpm, 3hp (2.24 kW)



Cold Saws *CPO 350 NF Series*

Aluminum, Non-Ferrous Metals & Plastic Cutting

CPO 350 NF

MANUAL SAW

- Manual clamp for material vise
- Operator controlled trigger switch



CPO 350 NF PK

MANUAL SAW W/POWER CLAMP

- Air-operated clamp for material vise
- Operator controlled trigger switch



CPO 350 NF PKPD

SEMI-AUTOMATIC SAW

- Air-operated clamp for material vise
- Pneumatic power down feed with electric controls
- Emergency stop button



COLD SAWS

STANDARD FEATURES

- Double self-centering vise assures burr-free cuts
- Miter capabilities 45° left to 45° right
- Miter locking device: quick, accurate setting-stops at 45° left, 90°, & 45° right
- Capable of slotting
- Positive-driven cogged belt system
- Chip drawer
- Mist coolant lubrication system
- One carbide tipped blade
- One gallon coolant
- Complies with ANSI B 11.10 safety standards
- Three-year warranty on parts
- Made in USA

MAXIMUM CAPACITIES

(with a 350 mm blade)

Tubing	90 Degree	45 Degree
Round	4-1/2" (114 mm)	4-1/4" (108 mm)
Square	4-1/4" x 4-1/4" (108 x 108 mm)	4" x 4" (102 x 102 mm)
Rectangle	5-1/2" x 4" (140 x 102 mm)	4" x 4" (102 x 102 mm)
Solid	90 Degree	45 Degree
Round	3" (76 mm)	2-1/2" (64 mm)
Square	3" x 3" (76 x 76 mm)	2-1/2" x 2-1/2" (64 x 64 mm)

SPECIFICATIONS

Motor Options (must specify)	208/230/460v, 3ph
Air Pressure	90 psi
Maximum Diameter Blade	350 mm
Arbor Bore	40 mm
Pin Spacing	4/12/64
Width	21-7/8" (55.5 cm)
Depth	43-1/2" (110.5 cm)
Height (not incl. feed handle)	56-1/4" (143 cm)
Height (floor to vise)	37-7/16" (95 cm)
Shipping Weight (may vary)	CPO 350 NF: 625 lbs. (283 kg) CPO 350 NF/PK: 655 lbs. (297 kg) CPO 350 NF PK/PD: 725 lbs. (329 kg)

CUTTING SPEEDS

Non-Ferrous Cutting Speeds	3,000 rpm, 5 hp (1.49 kW)
----------------------------	---------------------------



Cold Saws *CPO 275 Series*

Steel & Ferrous metal cutting

CPO 275

MANUAL SAW

- Manual clamp for material vise
- Operator controlled trigger switch



CPO 275 PK

MANUAL SAW W/ POWER CLAMP

- Air-operated clamp for material vise
- Operator controlled trigger switch



CPO 275 PKPD

SEMI-AUTOMATIC SAW

- Air-operated clamp for material vise
- Pneumatic power down feed with electric controls
- Emergency stop button



COLD SAWS

STANDARD FEATURES

- Double self-centering vise assures burr-free cuts
- Miter locking device stops 45° left, 90° and 45° right (Not available on PK or PKPD models)
- Capable of slotting
- Two cutting speeds
- Double reduction, hardened bronze gears
- Chip drawer
- Seven-gallon flood coolant tank with pump
- One HSS blade
- One gallon coolant
- Complies with ANSI B 11.10 safety standards
- Three-year warranty on parts
- Made in USA

MAXIMUM CAPACITIES

(with a 275 mm blade)

Tubing	90 Degree	45 Degree
Round	3-3/8" (86 mm)	2" (51 mm)
Square	3" x 3" (76 x 76 mm)	2" x 2" (51 x 51 mm)
Rectangle	3" x 2-3/8" (76 x 60 mm)	2" x 2" (51 x 51 mm)
Solid	90 Degree	45 Degree
Round	1-1/2" (38 mm)	1" (25 mm)
Square	1-1/2" x 1-1/2" (38 x 38 mm)	1" x 1" (25 x 25 mm)

SPECIFICATIONS

Motor Options (must specify)	LT & HT: 208/230/460/575v, 3ph SS: 220v, 1ph
Air Pressure	90 psi (PK and PKPD Only, n/a on CPO 275)
Maximum Diameter Blade	275 mm
Arbor Bore	32 mm
Pin Spacing	2/8/45
Width	21-7/8" (55.5 cm)
Depth	43-1/2" (110.5 cm)
Height (not incl. feed handle)	53-1/4" (135 cm)
Height (floor to vise)	36-1/8" (92 cm)
Shipping Weight (may vary)	CPO 275: 550 lbs. (249 kg) CPO 275 PK: 580 lbs. (263 kg) CPO 275 PKPD: 670 lbs. (304 kg)

CUTTING SPEEDS

(must specify)

LT (Low Turn) designed for solid mild & stainless steel, & thick wall pipe.	LT 30/60 rpm, 2hp (1.49 kW)
HT (High Turn) designed for thin wall tube 0.060 wall thickness or thinner and non-ferrous material	HT 60/120 rpm, 1.5hp (1.12 kW)
SS (Single Speed)	SS 60 rpm, 2hp (1.49 kW)



Cold Saw Options

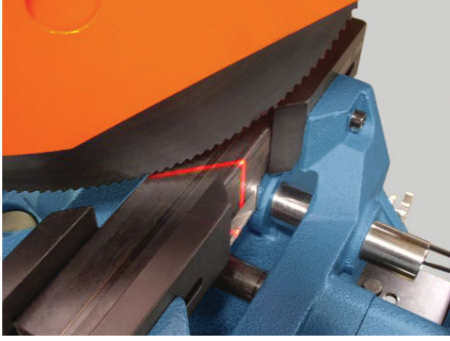

Blade Guide Laser Light
(Not Available on 275 series)

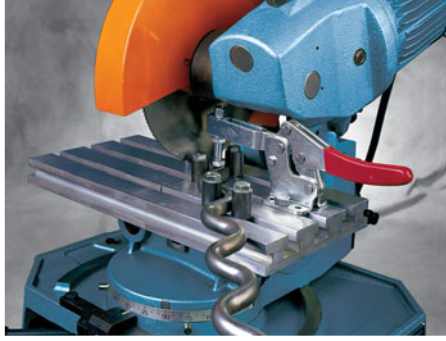

Universal Clamping Fixture

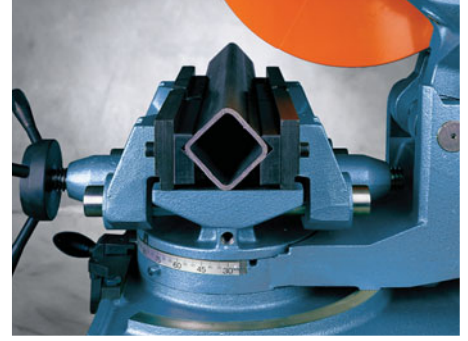

Square Tube/Diagonal Vise Jaws
(Not Available on NF series)



Variable Speed Control
(Not Available on NF or 275 series)
Recommended for cutting multiple shapes, sizes, and thicknesses. RPM can be fine-tuned to achieve optimum blade speed for each application and extend blade life.

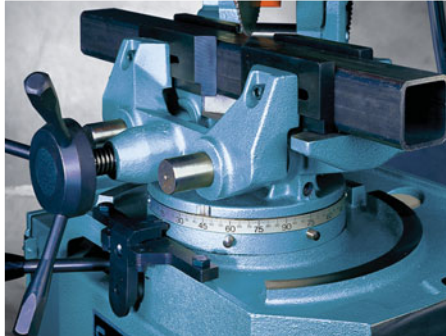

Miter Locking Device
Standard Feature
(not available for 275 PK or 275 PKPD models)



Saw Blades
(See page 41)

COLD SAWS

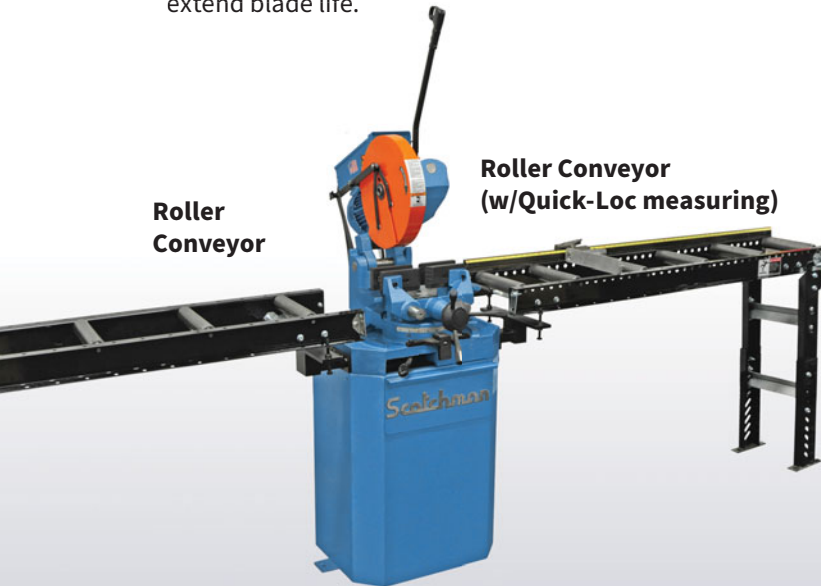

Roller Conveyor

Roller Conveyor (w/Quick-Loc measuring)

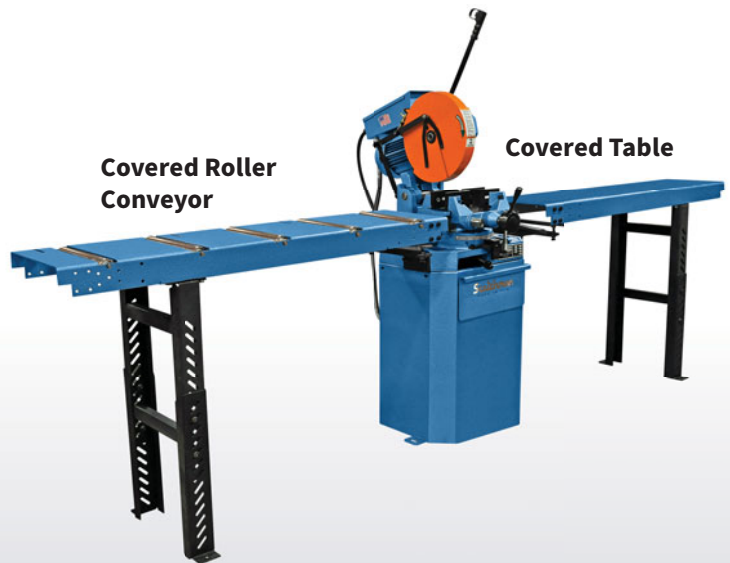

Covered Roller Conveyor

Covered Table

Automate your saw

Measuring devices available from manual to fully automatic.
(See pages 43-46)



Hitch Feed Automatic

COLD SAWS



Ideal for high volume and short length applications that require very accurate and clean cuts; this Hitch Feed Automatic (HFA) cold saw is fully automatic and provides uninterrupted cutting on tubing or solids.

CPO 315 HFA

STANDARD FEATURES

- Available in ferrous & non-ferrous
- Fully automatic cycle
- Push button controls
- Interlocking safety hood
- Emergency stop button
- Clamping both sides of blade - highest quality, burr-free cuts
- Blade guides for accurate tolerances (ferrous model)
- Mist coolant lubrication system
- Adjustable stroke control
- Adjustable down feed control on the saw head for feed rate
- Length scale in both inches and metric
- Quick and easy fine adjustment of length setting
- 30" single length shuttle
- Three shuttle max
- Piece counter
- One saw blade
- One gallon coolant
- Complies with ANSI B 11.10 safety standards
- Two-year warranty on parts
- Made in USA

SPECIFICATIONS

Length Tolerance	±0.006" per index
Squareness Tolerance	±0.002" per diameter inch
Minimum Cut Length	1/8" (3 mm)
Maximum Cut Length	Single Index 30" Double Index 60" Triple Index 90"
Motor Options (must specify)	208/230/460v, 3ph
Air Pressure	90 psi
Maximum Diameter Blade	315 mm
Arbor Bore Size	40 mm
Pin Spacing	4/12/64
Length	100" (254 cm)
Width	44" (112 cm)
Height	64" (162.5 cm)
Shipping Weight (may vary)	1,800 lbs. (816.5 kg)

OPTIONAL EQUIPMENT

- Flood coolant
- Form jaws for multiple tubes
- Digital read-out for quick easy length setting
- Ten-foot or twenty-foot material supply track

CUTTING SPEEDS

CPO 315 HFA (Ferrous)	Variable Speed 11 to 177 rpm 5 hp (3.73 kW)
CPO 315 HFA NF (Non-Ferrous)	3,000 rpm 5 hp (3.73 kW)

MAXIMUM CAPACITIES

(with a 315 mm blade)

Tubing	
Round	3-1/2" (≤ 89 mm)
Square	3-1/8" x 3-1/8" (≤ 79 mm x 79 mm)
Solid	
Round	1-3/4" (≤ 45 mm)
Square	1-1/2" x 1-1/2" (≤ 38 x 38 mm)
Solid (NF Models)	
Round	3-1/2" (≤ 89 mm)
Square	3-1/8" x 3-1/8" (≤ 79 mm x 79 mm)



Hitch Feed Automatic CNC



This fully automatic CNC saw allows for unlimited length settings; plus, the first piece cut is *always* accurate.

Easily program a quantity of pieces cut to a specific length OR program up to four separate lengths & part quantities to be cut in sequence.

COLD SAWS

CPO 315 HFA CNC

STANDARD FEATURES

- Available in ferrous & non-ferrous
- Fully automatic cycle
- Touch screen controls
- Precision CNC controlled
- Interlocking safety hood
- Emergency stop button
- Clamping both sides of blade - highest quality, burr-free cuts
- Blade guides for accurate tolerances (ferrous model)
- Mist coolant lubrication system
- Adjustable stroke control
- Adjustable down feed control on the saw head for feed rate
- Adjustable indexing feed speeds
- Program up to four separate cut lengths in each job
- 100 program job storage
- 30" single length shuttle
- Unlimited shuttles
- Piece counter
- One saw blade
- One gallon coolant
- Complies with ANSI B 11.10 safety standards
- Two-year warranty on parts
- Made in USA

SPECIFICATIONS

Length Tolerance	±0.006" per index
Squareness Tolerance	±0.002" per diameter inch
Minimum Cut Length	1/8" (3 mm)
Maximum Cut Length	unlimited
Motor Options (must specify)	208/230/460v, 3ph
Air Pressure	90 psi
Maximum Diameter Blade	315 mm
Arbor Bore Size	40 mm
Pin Spacing	4/12/64
Length	100" (254 cm)
Width	44" (112 cm)
Height	64" (162.5 cm)
Shipping Weight (may vary)	1,800 lbs. (816.5 kg)

OPTIONAL EQUIPMENT

- Flood coolant
- Form jaws for multiple tubes
- Ten-foot or twenty-foot material supply track

CUTTING SPEEDS

CPO 315 HFA (Ferrous)	Variable Speed 11 to 177 rpm 5 hp (3.73 kW)
CPO 315 HFA NF (Non-Ferrous)	3,000 rpm 5 hp (3.73 kW)

MAXIMUM CAPACITIES

(with a 315 mm blade)

Tubing	
Round	3-1/2" (≤ 89 mm)
Square	3-1/8" x 3-1/8" (≤ 79 mm x 79 mm)
Solid	
Round	1-3/4" (≤ 45 mm)
Square	1-1/2" x 1-1/2" (≤ 38 x 38 mm)
Solid (NF Models)	
Round	3-1/2" (≤ 89 mm)
Square	3-1/8" x 3-1/8" (≤ 79 mm x 79 mm)



Roller Feed Automatic *CPO 315 RFA*

Ideal for high volume and long length applications that require very accurate and clean cuts; this Roller Feed Automatic (RFA) cold saw is fully automatic, can store profile settings such as speeds and feeds, and is designed to your specifications.



(RFA shown with Supply Track)



Optional Bundle Loading Magazine

COLD SAWS

STANDARD FEATURES

- Available in ferrous and non-ferrous
- Fully automatic cycle
- Touch screen controls
- Interlocking safety hood
- Emergency stop button
- Automatic loading and trim cut of each new bar
- Automatic tube ejection
- Trim and remnant gate
- Clamping both sides of blade - highest quality, burr-free cuts
- Blade guides for accurate tolerances (ferrous model)
- Adjustable stroke control on the saw head
- Adjustable downfeed control on saw head for feed rate
- Length scale in both inches and metric
- Digital read-out for quick and easy fine adjustment of length setting
- Piece counter
- Mist coolant lubrication system
- One saw blade
- One gallon coolant
- Complies with ANSI B 11.10 safety standards
- Two-year warranty on parts
- Made in USA

OPTIONAL EQUIPMENT

- In-line deburring unit
- Flood coolant
- Longer cut lengths - 90" or 120"
- Bundle loader magazine

MAXIMUM CAPACITIES

(with a 315 mm blade)

Tubing	
Round	3" (76 mm)
Square	2-1/2" x 2-1/2" (64 x 64 mm)
Solid	
Round	1-3/4" (44 mm)
Square	1-1/2" x 1-1/2" (38 x 38 mm)
Solid (NF Models)	
Round	3" (76 mm)
Square	2-1/2" x 2-1/2" (64 x 64 mm)



SPECIFICATIONS

Length Tolerance	±0.006" repeatability	
Squareness Tolerance	±0.002" per diameter inch	
Minimum Cut Length	1-1/4" (32 mm)	
Maximum Cut Length	60" (90" or 120" available)	
Minimum Trim Cut	1" (25 mm)	
Motor Options (must specify)	208/230/460v, 3ph	
Air Pressure	90 psi	
Maximum Diameter Blade	315 mm	
Arbor Bore Size	40 mm	
Pin Spacing	4/12/64	
12' Supply Table (ST)	Maximum Raw Stock (12' ST)	12'
	Load Table Capacity	24"
	Dimensions - 12' ST w/60" Saw	(L) 240" (W) 48" (H) 60"
24' Supply Table (ST)	Maximum Raw Stock (24' ST)	24'
	Load Table Capacity	24"
	Dimensions - 24' ST w/60" Saw	(L) 380" (W) 48" (H) 60"
Bundle Loader (BL)	Maximum Raw Stock (BL)	Up to 24'
	Load Table Capacity	4,000 lbs
	Dimensions - 24' BL w/60" Saw	(L) 384" (W) 93" (H) 60"

CUTTING SPEEDS

CPO 315 RFA/ST (Ferrous)	Variable Speed 11 to 177 rpm 5 hp (3.73 kW)
CPO 315 RFA/ST NF (Non-Ferrous)	3,000 rpm 5 hp (3.73 kW)

CPO 350 AutoLoader

The CPO 350 AutoLoader is a fully automatic sawing system guaranteed to save time, eliminate costly mistakes, and deliver consistent results for years to come. Quick set-up, automatic part length change, and the fast reloading of material adds efficiency.



COLD SAWS

STANDARD FEATURES

- Available in ferrous and non-ferrous
- Fully automatic cycle or semi-automatic operation
- Pneumatic power down feed with electric controls
- Adjustable stroke control
- Adjustable down feed control on saw head for feed rate
- Air operated material vise clamp
- Clamping on both sides of the blade
- Fixed rear vise
- Double reduction, hardened bronze gears (ferrous model)
- Chip drawer
- Emergency stop button
- Clear awareness barrier with safety interlock switch
- Mist coolant lubrication system
- Material feed direction can be either:
R → L or L → R (must specify)
- Miter in only one direction (manually)
- Semi-auto operation is standard for cutting miters
- Automatic loading & trim cut of each new bar
- Piece counter
- Touch screen controls
- Windows® based software (Includes profile screen)
- Unlimited job storage
- One saw blade
- One gallon coolant
- Complies with ANSI B 11.10 safety standards
- Two-year warranty on parts (Saw)
- One-year warranty on parts (Feed system)
- Made in USA

OPTIONAL EQUIPMENT

- Bundle loader magazine (see page 35)
- Flood coolant

MAXIMUM CAPACITIES

(with a 350 mm blade)

Tubing	90 Degree	45 Degree
Round	3" (76 mm)	2" (51 mm)
Square	3" (76 mm)	2" (51 mm)
Solid	90 Degree	45 Degree
Round	1-3/4" (45 mm)	1-1/2" (38 mm)
Solid (NF)	90 Degree	45 Degree
Round	3" (76 mm)	2" (51 mm)
Square	3" (76 mm)	2" (51 mm)



AutoLoader Supply Track

SPECIFICATIONS

Length Tolerance	±0.015" repeatability	
Squareness Tolerance	±0.002" per diameter inch	
Minimum Cut Length	1/2" (12 mm)	
Maximum Cut Length	23' 9" (724 cm)	
Motor Options (must specify)	208/230/460v, 3ph	
Air Pressure	90 psi	
Maximum Diameter Blade	350 mm	
Arbor Bore Size	40 mm	
Pin Spacing	4/12/64	
12' Supply Table (ST)	Maximum Raw Stock (12' ST)	12'
	Load Table Capacity	24"
	Dimensions - 12' ST w/Saw	(L) 236" (W) 47" (H) 68"
24' Supply Table (ST)	Maximum Raw Stock (24' ST)	24'
	Load Table Capacity	24"
	Dimensions - 24' ST w/Saw	(L) 377" (W) 47" (H) 68"

CUTTING SPEEDS

CPO 350 (Ferrous)	Variable Speed 11 to 177 rpm 5 hp (3.73 kW)
CPO 350 NF (Non-Ferrous)	3,000 rpm 5 hp (3.73 kW)



Upcut Miter *SUP Series*

Large capacity precision mitering upcut saw for aluminum, non-ferrous metals, and plastic cutting. Available in 20" or 24" blade models.

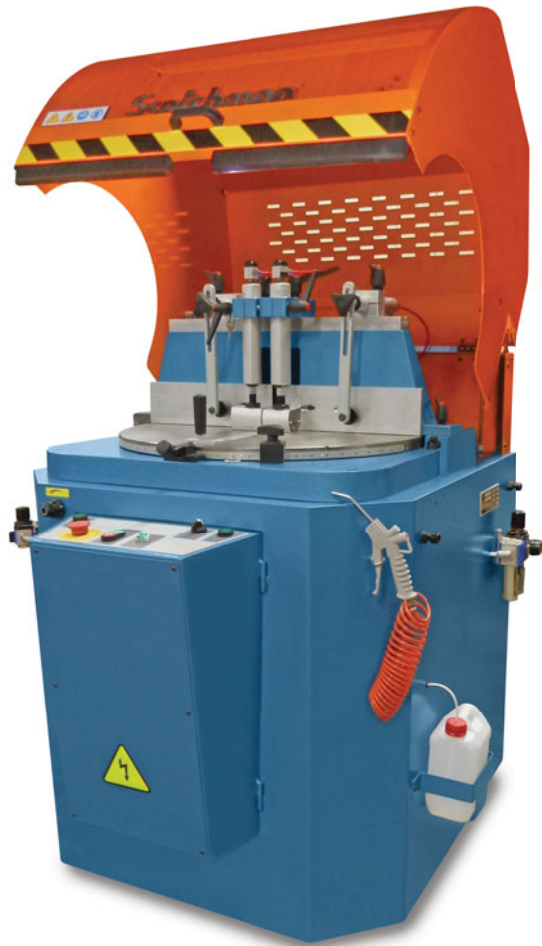

COLD SAWS

STANDARD FEATURES

- Non-Ferrous saw
- Miter capabilities with fixed stops at 22.5°, 45°, 90°, 135°, and 157.5°
- Safety hood with safety interlock switch
- Power hood (SUP-600 NF model)
- Blade door with safety interlock switch
- Dual palm buttons
- Adjustable feed rate on saw head
- Two horizontal pneumatic clamps
- Two vertical pneumatic clamps
- Capable of slotting
- Moveable back fence for larger capacity
- One gallon coolant
- Mist lubrication system
- One carbide tipped blade
- Air hose
- Chip collection drawer in base and 4-3/4" chip collection port
- Adjustable leveling pads
- Meets CE standards
- Three-year warranty on parts
- Made in Spain

CUTTING SPEEDS

SUP-500 NF	3,000 rpm 5.5 hp (4.1 kW)
SUP-600 NF	3,000 rpm 5.5 hp (4.1 kW)



Optional Manual to Full Auto Feed Systems Available.

(See pages 43-46)

SUP-500 NF

MAXIMUM CAPACITIES

(With a 500 mm Dia Blade)

	90 Degree	45 Degree
Round	7" (178 mm)	7" (178 mm)
Square	6" (152 mm)	4-3/4" (121 mm)
Rectangle	11-3/4" x 5" (298 x 127 mm)	5-3/4" x 4-3/4" (146 x 121 mm)

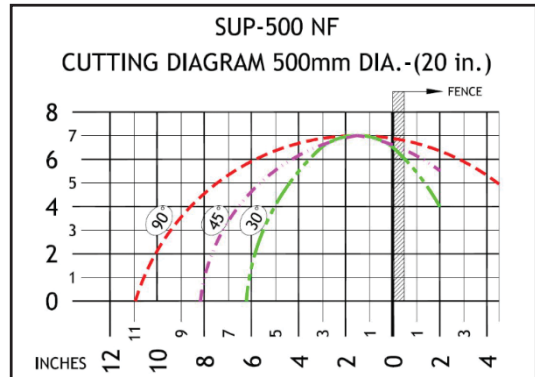

SUP-600 NF

MAXIMUM CAPACITIES

(With a 600 mm Dia Blade)

	90 Degree	45 Degree
Round	9" (229 mm)	9" (229 mm)
Square	8" (203 mm)	7" (178 mm)
Rectangle	15" x 6" (381 x 152 mm)	10" x 4" (254 x 102 mm)

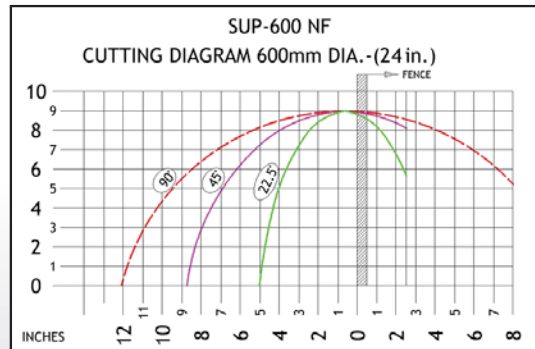

SPECIFICATIONS

	SUP-500	SUP-600
Motor Options (must specify)	230/460v, 3ph	
Air Pressure	90 psi	
Maximum Diameter Blade	500 mm	600 mm
Arbor Bore	50 mm	50 mm
Width	42" (107 cm)	49-1/4" (126 cm)
Depth	45-3/8" (115 cm)	54-1/2" (139 cm)
Height (top of the hood)	60-1/4" (153 cm)	64-3/8" (164 cm)
Height (floor to table)	38-5/8" (98 cm)	
Shipping Weight (may vary)	1,200 lbs. (545 kg)	1,465 lbs. (665 kg)

AngleMaster Upcut Miter

SUP-600 AngleMaster

Large capacity upcut saw for aluminum, plastic, and non-ferrous metals. Combines an automatic mitering ability with a programmable feed.

MAXIMUM CAPACITIES (With a 600 mm Dia Blade)		
	90 Degree	45 Degree
Round	8" (203 mm)	7" (178 mm)
Square	7" (178 mm)	6" (152 mm)
Rectangle	9" x 5" (229 x 127 mm)	7" x 4-3/4" (178 x 121 mm)

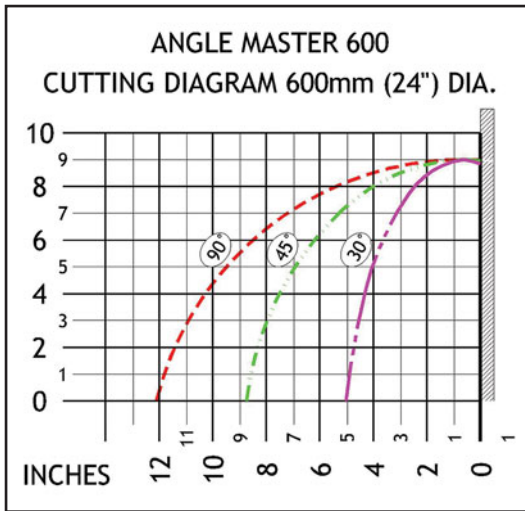

SPECIFICATIONS	
	SUP-600
Motor Options (must specify)	230/460v, 3ph
Air Pressure	90 psi
Maximum Diameter Blade	600 mm
Arbor Bore	50 mm
Width	49-1/4" (126 cm)
Depth	54-1/2" (139 cm)
Height (top of the hood)	64-3/8" (164 cm)
Height (floor to table)	38-5/8" (98 cm)

CUTTING SPEEDS	
SUP-600 NF	3,000 rpm 5.5 hp (3.73 kW)



This precision semi-automatic programmable sawing system automatically rotates to cut any angle, pushes material into the saw, then automatically rotates to the next desired angle.

STANDARD FEATURES

- Non-ferrous saw
- Semi automatic operation
- Mitering degree range 22° to 159°
- Feed length available - 10' to 30'
- Right-to-Left feed only
- Touch screen controls
- Windows® based software (includes profile screen)
- Unlimited job storage
- Powered safety hood with safety interlock switch
- Blade door with safety interlock switch
- Dual palm buttons
- Adjustable feed rate on saw head
- Two horizontal pneumatic clamps
- Two vertical pneumatic clamps
- Capable of slotting
- One gallon coolant
- Mist coolant lubrication system
- One carbide tipped blade
- Air hose
- Chip collection drawer in base and 4-3/4" chip collection port
- Adjustable leveling pads
- Meets CE standards
- Two-year warranty on parts (saw)
- One-year warranty on parts (feed system)
- Saw Made in Spain
- Feed system Made in USA

Straight Cuts – Miter Cuts – and Everything In-Between



OPTIONAL FEATURE

- **Auto 90° program** allows machine to run in full auto mode when cutting at 90°.

Automatic Upcut

Large capacity automatic upcut saw for cutting non-ferrous materials at 90°. Fits almost any profile and is capable of drilling and tapping holes with DT20 option.

COLD SAWS



GAA-500-90

MAXIMUM CAPACITIES

(With a 500 mm Dia Blade)

	90 Degree
Round	6" (152 mm)
Square	6" x 6" (152 x 152 mm)
Rectangle	10" x 3" (254 x 76 mm)

GAA-500-90

CUTTING CAPACITY- Ø500mm (20") BLADE

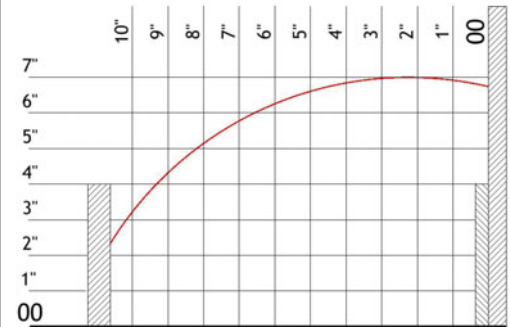

STANDARD FEATURES

- Non-ferrous saw
- Shuttle feed design cuts at 90° only
- Automatic or Semi-automatic operation
- Automatic feeder, 20" x 2 strokes (20" + 20" Max. double advance)
- LED lighting
- Powered hood lift
- Emergency stop
- Adjustable cutting & feeding speeds
- Adjustable length selector from 0.200 to 20"
- Three horizontal pneumatic clamps
- Three vertical pneumatic clamps
- One gallon coolant
- Mist coolant lubrication system
- One carbide tipped blade
- Air hose
- Base designed as a chip collection with two extraction ports
- Adjustable leveling pads
- Meets CE standards
- Two-year warranty on parts
- Made in Spain

SPECIFICATIONS

	GAA-500-90	GAA-500-90 DT20
Length Tolerance	±0.006" per index	±0.006" per index
Motor Options (must specify)	230/460v, 3ph	
Air Pressure	90 psi	90 psi
Maximum Diameter Blade	500 mm	500 mm
Arbor Bore	50 mm	50 mm
Width	80-1/2" (205 cm)	72-1/2" (185 cm)
Depth	43-3/8" (110 cm)	52-1/2" (133 cm)
Height (top of hood)	60-1/4" (153 cm)	81" (206 cm) (top of drill)
Height (floor to vise)	38-5/8" (98 cm)	38-5/8" (98 cm)
Shipping Weight (may vary)	1,300 lbs. (590 kg)	1,535 lbs. (696 kg)



Optional Drill/Tap



CUTTING SPEEDS

GAA-500-90	3,000 rpm 7.5 hp (5.59 kW)
GAA-500-90 DT20	3,000 rpm 7.5 hp (5.59 kW)

OPTIONAL EQUIPMENT

- Drill/Tap 20mm (DT20) (shown at left)
- CNC Controls can be added to DT20 models.

Automatic Upcut CNC

Precision CNC controlled upcut circular saw for cutting aluminum, plastic, or non-ferrous metals at 90°.



STANDARD FEATURES

- Non-ferrous saw
- Shuttle feed design cuts at 90° only
- Automatic or semi-automatic operation
- Precision CNC controls
- 27" of ballscrew servomotor automatic feeder
- Unlimited stroke
- LED lighting
- Powered hood lift
- Emergency stop
- Adjustable cutting & feeding speeds
- Adjustable length selector from 0.200 to 20"
- Three horizontal pneumatic clamps
- Three vertical pneumatic clamps
- One gallon coolant
- Mist coolant lubrication system
- One carbide tipped blade
- Air hose
- Base designed as a chip collection with two extraction ports
- Adjustable leveling pads
- Meets CE standards
- Two-year warranty on parts
- Made in Spain

GAA-600-90 CNC

MAXIMUM CAPACITIES

(With a 600 mm Dia Blade)

	90 Degree
Round	8" (203 mm)
Square	8" x 8" (203 x 203 mm)
Rectangle	14" x 4" (356 x 102 mm)

GAA-600 CNC

CUTTING CAPACITY Ø600mm (24") Blade

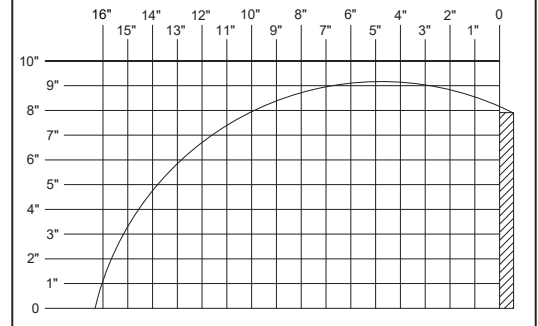

COLD SAWS

SPECIFICATIONS

	GAA-600 CNC
Length Tolerance:	±0.006" per index
Motor Options: (must specify)	230/460v, 3ph
Air Pressure:	90 psi
Maximum Diameter Blade:	600 mm
Arbor Bore:	50 mm
Width:	75" (191 cm)
Depth:	60" (152 cm)
Height (top of hood):	65" (165 cm)
Height (floor to vise):	38-5/8" (98 cm)
Shipping Weight: (may vary)	1750 lbs. (794 kg)

CUTTING SPEEDS

GAA-600 CNC	3,000 rpm 7.5 hp (5.59 kW)
-------------	-------------------------------

MACHINES
THAT WORK
AS HARD
AS YOU DO.

ScotchmanTM

Metal Fabricating Solutions

Sales partner in México:

ACAT

ACAT Mexicana
Ave. Regio Parque #200 Regio Parque Industrial
Apodaca , Nuevo León, México CP. 66633



acat@acatmexicana.com



TEL. 81 8354 8910



www.acatmexicana.com