

PROUD AMERICAN MANUFACTURER

ACAT

TEL. 81 8354 8910
www.acatmexicana.com

Scotchman

Scotchman
MADE IN U.S.A.

Scotchman™

Metal Fabricating Solutions

Ironworkers | Cold Saws | Automatic Sawing Systems | Hydraulic Press | Pipe Notchers | Measuring Devices

Ironworkers

IRONWORKERS

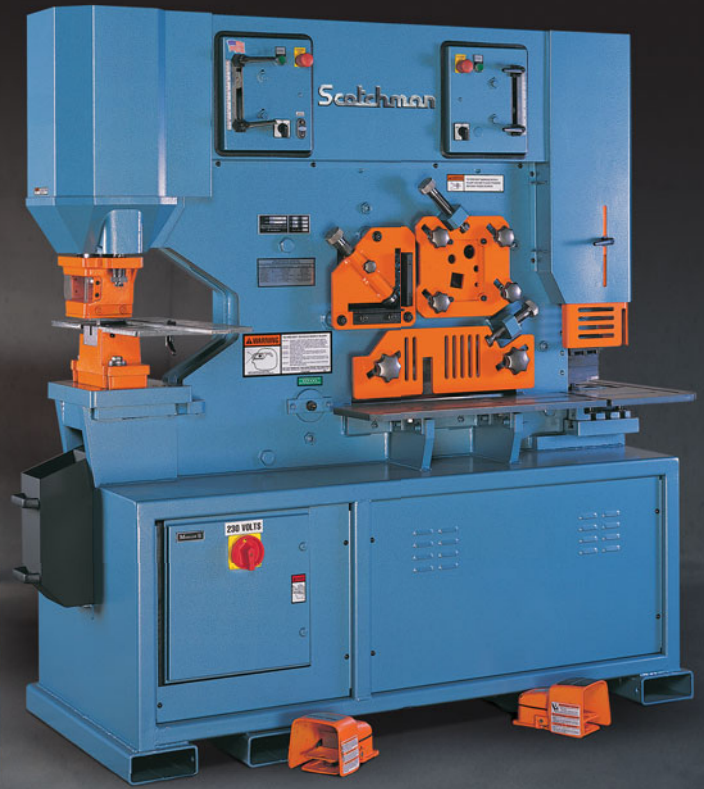
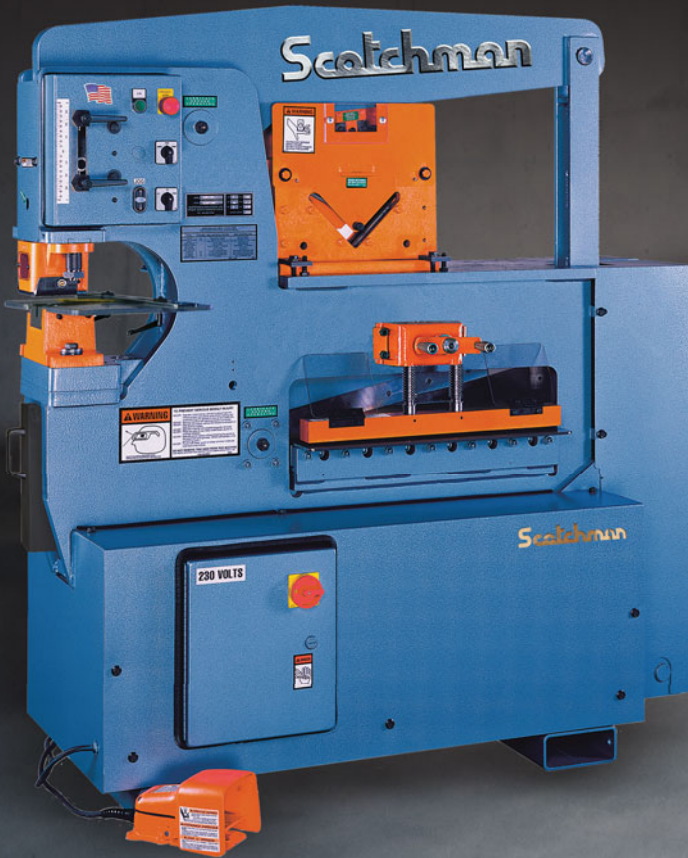

Single & Dual Operator Hydraulic Ironworkers

American Made with 3-Year Warranty

Backed by the Scotchman reputation of superior quality and dependability, our ironworkers are built tough to last generations. Models range in capacity from 45-150 tons and are available in two distinct styles.

- Our unique Component Tool Table style provides flexibility to swap-out tooling quickly for those quick turnaround jobs. The variety of tooling options available for this style gives it unmatched versatility to any other machine on the market.
- Fully-Integrated Ironworkers feature built-in tools and are suited best for repetitive, higher volume projects.

CAPACITY CHART QUICK REFERENCE GUIDE ... 5-6

45 TON	7-8
50 TON	9-10
65 TON	11
70 TON	12
85 TON	13-14
90 TON	15
95 TON	16
120 TON	17-18
135 TON	19
150 TON	20
OPTIONAL TOOLING	21-22
CUSTOM TOOLING	23
IN-STOCK PUNCH & DIES	24
PRODUCTION SHEAR	25



Component Tool Style Workstations

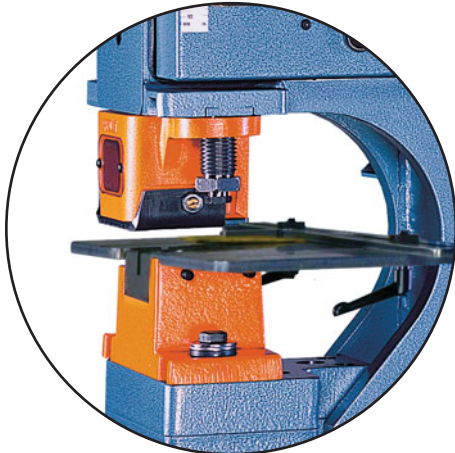

PUNCH:

The punch station is one of the most functional standard tools on any ironworker. A full range of punches & dies in standard shapes and increments are available in-stock for your various punching needs, plus tooling can be custom built for your special application. This workstation can also be used for additional applications beyond strictly punching.

FLAT BAR SHEAR:

A flat bar shear is a standard workstation on all ironworkers, but not all bar shears are created equal. All Scotchman ironworkers have a shear with a variable rake angle which minimizes distortion of the cut and increases cut time for a faster shear cycle. From 6" to 24" in width, each Scotchman ironworker is equipped with the best shear for its capacity. Hold-downs are easily adjustable with good visibility, and the reversible shear blades provide a long life of plate shearing.

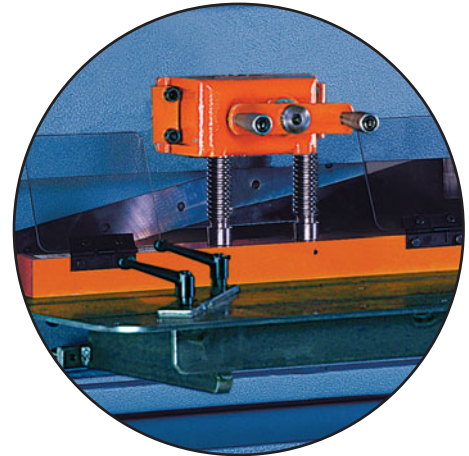

ANGLE SHEAR:

This useful tool is standard on every Scotchman ironworker. Produces a distortion free cut, and can easily & quickly 45° miter cut.



NOTCHER:

Ideal for notching and nibbling of plate and angle iron. When versatility is key, a copier notcher is essential. Standard workstation on most Scotchman ironworker models, but available as an option on the models it is not standard.

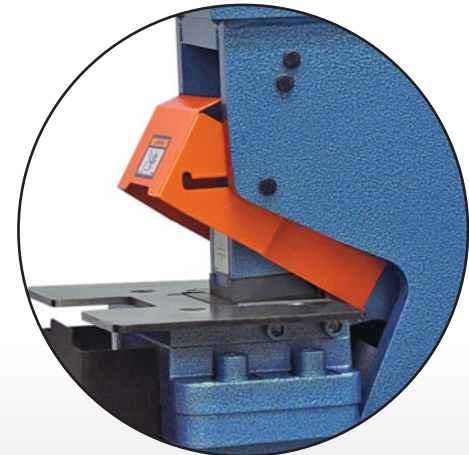

TOOL TABLE WORKSTATION FOR COMPONENT TOOLS:

When versatility and flexibility are key, our unique tool table workstation is indispensable! This tool table design is unique to Scotchman and creates a workstation that is fully customizable allowing an extensive variety of different tooling options to be used and switched out easily, without losing the punch station. This workstation acts as an additional power source which allows users to tailor the machine to their individual needs.



Scotchman has a variety of tooling options available as well as a full-time custom tooling department making the options nearly endless.

Ironworker Capacities

IRONWORKERS

		45 ton	50 ton	50 ton	65 ton	70 ton	85 ton
		Single Operator	Single Operator	Single Operator	Single Operator	Dual Operator	Single Operator
Machine Design Style		Component Tool Table	Component Tool Table	Component Tool Table	Component Tool Table	Component Tool Table	Fully Integrated Tools
Punch	Throat Depth	4-1/4"	6"	4"	9"	9"	10"
	Tonnage	45 ton	50 ton	50 ton	65 ton	70 ton	85 ton
	Capacity	1-1/8" in 1/2"	1-1/4" in 1/2" 13/16" in 3/4"	1-1/4" in 1/2" 13/16" in 3/4"	1-1/16" in 3/4"	1-1/8" in 3/4"	1-1/16" in 1"
	Max. Hole	2-1/4"	2-1/4"	2-1/4"	4"	4"	4"
Bar Shear	Blade Length	6"	14"	14"	24"	24"	20"
	Max. Capacity	1/2" x 4"	3/4" x 4"	3/4" x 4"	1" x 6"	1" x 6"	1" x 12"
		3/8" x 6"	1/2" x 8" 3/8" x 10" 1/4" x 14"	1/2" x 8" 3/8" x 10" 1/4" x 14"	3/4" x 10" 1/2" x 12" 3/8" x 16" 1/4" x 24"	3/4" x 10" 1/2" x 14" 3/8" x 24"	3/4" x 20"
Angle Shear	Angle Shear, 90°	3" x 3" x 5/16"	4" x 4" x 3/8"	4" x 4" x 3/8"	6" x 6" x 3/8" 5" x 5" x 1/2"	6" x 6" x 1/2"	6" x 6" x 1/2"
	Angle Shear, 45°	2" x 2" x 1/4"	2" x 2" x 1/4"	2" x 2" x 1/4"	3" x 3" x 3/8" 4" x 4" x 1/2" (with bar shear)	3" x 3" x 3/8" 4" x 4" x 1/2" (with bar shear)	4" x 4" x 1/2" (with bar shear)
Channel Shear	Size Avail.	up to 3"	up to 3"	up to 3"	2" to 5" adjustable	2" to 6" adjustable	2" to 6" adjustable
Rod Shear	Round Rod	1/4" to 1", 5 cavity	1/4" to 1", 5 cavity	1/4" to 1", 5 cavity	1/4" to 1-1/4", 9 cavity	1/4" to 1-1/4", 9 cavity	1-1/2", 1 cavity
	Square Rod	1/4" to 3/4", 1 cavity	1/4" to 3/4", 1 cavity	1/4" to 3/4", 1 cavity	1/4" to 1", 1 cavity	1/4" to 1", 1 cavity	1-1/4", 1 cavity
Tube Shear	Square Tube	1/2" to 1", 12 gauge	1/2" to 1", 12 gauge	1/2" to 1", 12 gauge	1/2" to 2", 12 gauge	1/2" to 2", 12 gauge	1/2" to 2", 12 gauge
Notcher	Rectangle	2" x 1-3/4" x 1/4"	2-1/2" x 3" x 5/16" 2-1/2" x 2-3/4" x 3/8"	2-1/2" x 3" x 5/16" 2-1/2" x 2-3/4" x 3/8"	2" x 2-1/2" x 3/8"	3" x 5" x 3/8" 3" x 4" x 1/2"	3" x 5" x 1/2"
	90° V	6" x 6" x 1/8"	6" x 6" x 1/8" 3" x 3" x 1/4"	6" x 6" x 1/8" 3" x 3" x 1/4"	6" x 6" x 5/16"	6" x 6" x 5/16"	3" x 3" x 1/2" (Notcher Station) 6" x 6" x 5/16" (Punch Station)
		Pipe (Sch. 40)	3/4" to 2"	3/4" to 2"	3/4" to 2"	3/4" to 2"	3/4" to 2"
Bending	Brake Size Avail.	6", 8", 12", 6" Open-End	6", 8", 12", 6" Open-End	6", 8", 12", 6" Open-End	12", 24", 6" Open-End	12", 24", 6" Open-End	12", 24", 6" Open-End
Picket Tool	Size	1/2", 3/4", & 1" (16 gauge)	1/2", 3/4", & 1" (16 gauge)	1/2", 3/4", & 1" (16 gauge)	1/2", 3/4", & 1" (16 gauge)	1/2", 3/4", & 1" (16 gauge)	1/2", 3/4", & 1" (16 gauge)
Motor	Standard	110v	230/460v, 3 ph	230/460v, 3 ph	230/460v, 3 ph	230/460v, 3 ph	230/460v, 3 ph
	Optional	220v, 1 ph	220v, 1 ph	220v, 1 ph	220v, 1 ph	220v, 1 ph	220v, 1 ph
<p>*Not all functions & capacities are standard, but can be achieved with optional tooling.</p> <p>*Custom built tooling is available upon request.</p>							
Model Name		Porta Fab 45	50514-EC	5014-ET	6509	DO 70	FI 85
		Page 7	Page 9	Page 9	Page 11	Page 12	Page 13

Quick Reference Guide

IRONWORKERS

85 ton		90 ton		95 ton		120 ton		120 ton		135 ton		150 ton		Production Shear			
Dual Operator		Single Operator		Dual Operator		Single Operator		Dual Operator		Dual Operator		Dual Operator		Single Operator			
Fully Integrated Tools		Component Tool Table		Component Tool Table		Component Tool Table		Component Tool Table		Component Tool Table		Component Tool Table		Shear Only			
14"		12"		9"		12"		12"		12"		12"		N/A			
85 ton		90 ton		95 ton		120 ton		120 ton		135 ton		150 ton					
1-1/16" in 1"		1-1/8" in 1"		1-3/16" in 1"		1-1/2" in 1"		1-1/2" in 1"		1-11/16" in 1"		1-7/8" in 1"					
4"		4"		4"		4"		4"		4"		4"		N/A			
20"		24"		24"		24"		24"		24"		24"					
1" x 14" 3/4" x 20"		1" x 8" 3/4" x 12" 1/2" x 16" 1/4" x 24"		1" x 8" 3/4" x 12" 1/2" x 16" 3/8" x 24"		1" x 12" 3/4" x 20" 1/2" x 24"		1" x 12" 3/4" x 20" 1/2" x 24"		1" x 12" 3/4" x 20" 1/2" x 24"		1" x 14" 3/4" x 24"				1" x 12" 3/4" x 16" 1/2" x 24"	
6" x 6" x 1/2"		6" x 6" x 1/2"		6" x 6" x 1/2"		6" x 6" x 1/2"		6" x 6" x 1/2"		6" x 6" x 1/2"		6" x 6" x 1/2"					
4" x 4" x 1/2" (with bar shear)		3" x 3" x 3/8" 4" x 4" x 1/2" (with bar shear)		3" x 3" x 3/8" 4" x 4" x 1/2" (with bar shear)		3" x 3" x 3/8" 4" x 4" x 1/2" (with bar shear)		3" x 3" x 3/8" 4" x 4" x 1/2" (with bar shear)		3" x 3" x 3/8" 4" x 4" x 1/2" (with bar shear)		3" x 3" x 3/8" 4" x 4" x 1/2" (with bar shear)					
2" to 6"		2" to 6" adjustable		2" to 6" adjustable		2" to 6" adjustable		2" to 6" adjustable		2" to 6" adjustable		2" to 6" adjustable					
1/2", 3/4", 1", 1-1/2", 4 cavity		1/4" to 1-1/4", 9 cavity		1/4" to 1-1/4", 9 cavity		1/4" to 1-1/4", 9 cavity		1/4" to 1-1/4", 9 cavity		1/4" to 1-1/4", 9 cavity		1/4" to 1-1/4", 9 cavity					
1-1/2", 1 cavity		1/4" to 1", 1 cavity		1/4" to 1", 1 cavity		1/4" to 1", 1 cavity		1/4" to 1", 1 cavity		1/4" to 1", 1 cavity		1/4" to 1", 1 cavity					
1/2" to 2", 12 gauge		1/2" to 2", 12 gauge		1/2" to 2", 12 gauge		1/2" to 2", 12 gauge		1/2" to 2", 12 gauge		1/2" to 2", 12 gauge		1/2" to 2", 12 gauge					
2" x 4" x 1/2"		2" x 2-1/2" x 3/8"		3" x 5" x 3/8" 3" x 4" x 1/2"		2" x 2-1/2" x 3/8"		3" x 5-3/4" x 1/2"		3" x 5-3/4" x 1/2"		3" x 5-3/4" x 1/2"					
3" x 3" x 1/2" (Notcher Station) 6" x 6" x 5/16" (Punch Station)		6" x 6" x 5/16"		6" x 6" x 5/16"		6" x 6" x 5/16"		6" x 6" x 5/16"		6" x 6" x 5/16"		6" x 6" x 5/16"					
3/4" to 2"		3/4" to 2"		3/4" to 2"		3/4" to 2"		3/4" to 2"		3/4" to 2"		3/4" to 2"					
12", 24", 6" Open-End		12", 24", 6" Open-End		12", 24", 6" Open-End		12", 24", 6" Open-End		12", 24", 6" Open-End		12", 24", 6" Open-End		12", 24", 6" Open-End					
1/2", 3/4", & 1" (16 gauge)		1/2", 3/4", & 1" (16 gauge)		1/2", 3/4", & 1" (16 gauge)		1/2", 3/4", & 1" (16 gauge)		1/2", 3/4", & 1" (16 gauge)		1/2", 3/4", & 1" (16 gauge)		1/2", 3/4", & 1" (16 gauge)					
230/460v, 3 ph 220v, 1 ph		230/460v, 3 ph 220v, 1 ph		230/460v, 3 ph 220v, 1 ph		230/460v, 3 ph 220v, 1 ph		230/460v, 3 ph 220v, 1 ph		230/460v, 3 ph 220v, 1 ph		230/460v, 3 ph 220v, 1 ph					
																	
DO 85		9012		DO 95		12012		DO 120		DO 135		DO 150		ShearMaster 610			
Page 14		Page 15		Page 16		Page 17		Page 18		Page 19		Page 20		Page 25			



**DUAL
OPERATOR**
5 STATIONS

DO 70/110-24M

Capacities and Specifications

Rated On: A36 Mild Steel / 65,000 PSI Tensile

Punching Capacity	70 ton (63 mt) 1-1/8" in 3/4" (29 mm in 19 mm)
Special Tooling	4" (102 mm) Max. Dia.
Throat Depth	9" (229 mm)
Flat Bar Shear (sabre blade-std.)	24" Length (610 mm) 1" x 6" (25 x 152 mm) 3/4" x 10" (19 x 254 mm) 1/2" x 14" (12 x 356 mm) 3/8" x 24" (10 x 610 mm)
Angle Shear 90°	6" x 6" x 1/2" (152 x 152 x 12 mm)
Angle Shear 45°	
w/Tool	3" x 3" x 3/8" (76 x 76 x 10 mm)
w/Bar Shear	4" x 4" x 1/2" (102 x 102 x 12 mm)
Brake 12"	65 ton (59 mt)
Brake 24"	45 ton (40 mt)
Open End Brake	Max. 1/4" x 5" (6 x 127 mm) [Flat or Angle Iron]
Pipe Notcher Schedule 40	3/4", 1", 1-1/4", 1-1/2", 2"
Rectangle Notcher	3" x 5" x 3/8" (76 x 127 x 10 mm) 3" x 4" x 1/2" (76 x 101 x 12 mm)
90° V-Notcher	6" x 6" x 5/16" (152 x 152 x 8 mm) 3" x 3" x 3/8" (76 x 76 x 10 mm)
Notching in Leg of Channel	6" to 10" (152 mm to 254 mm)
Channel Shear	2" to 6" adj. (51 mm to 152 mm adj.)
Unistrut Shear	Samples Required
Rod Shear Round (max.)	9 Cavity, 1/4" to 1-1/4" (6 mm to 32 mm)
Rod Shear Square (max.)	1 Cavity, 1/4" to 1" (6 mm to 25 mm)
Square Tube Shear	1/2" to 2" (12 mm to 51 mm) 12 gauge (0.105" / 2.7 mm)
Picket Tool	1/2", 3/4" & 1" (12 mm, 19 mm, 25 mm) 16 gauge (0.06" / 1.5 mm)
Weld Coupon Bender (max.)	2" wide x 3/8" (51 mm x 10 mm)
Offset Die Holder	Max. 40 ton (36 mt)
Strokes per minute in light material	38 spm (1/4" stroke) [Punch Station]
Strokes per minute in heavy material	15 spm (3/4" stroke) [Punch Station]
Hydraulics	3,000/3,000 psi (207/207 bar)
Motor Options (must specify)	10 hp 3 ph (7.46 kW) 208/230/460, 380/575v 10 hp 1 ph (7.46 kW) 220v
Dimensions	L-69" (175 cm) W-37-1/2" (95 cm) H-71" (180 cm)
Shipping Weight (may vary)	3,800 lbs. (1,724 kg)

IRONWORKERS

STANDARD FEATURES

- Dual operator allows for two operators to work at the same time at full capacity
- 70 ton punch station
- Keyed punch ram for safety
- Punch gauging table with fence and scale
- Die holder complete with 2" die insert
- Punch nut with wrench & stripper
- Adjustable swing-away stripper
- One round punch & die: max. diameter 1-1/4"
- Jog control
- Two adjustable electric stroke controls with scale
- Two electric remote foot pedals
- Two 2-stage hydraulic pumps
- Two valves
- Angle shear
- Rectangle notcher with table, scale and guides
- Flat bar shear with sabre blade
- Shear table with miter fence
- Tool table work area
- Slug receptacles
- Electrical box supplied with emergency palm button and lock-out tag-out accommodations
- Complies with ANSI B 11.5 safety standards
- Forklift accommodations
- Three-year warranty on parts
- Made in USA



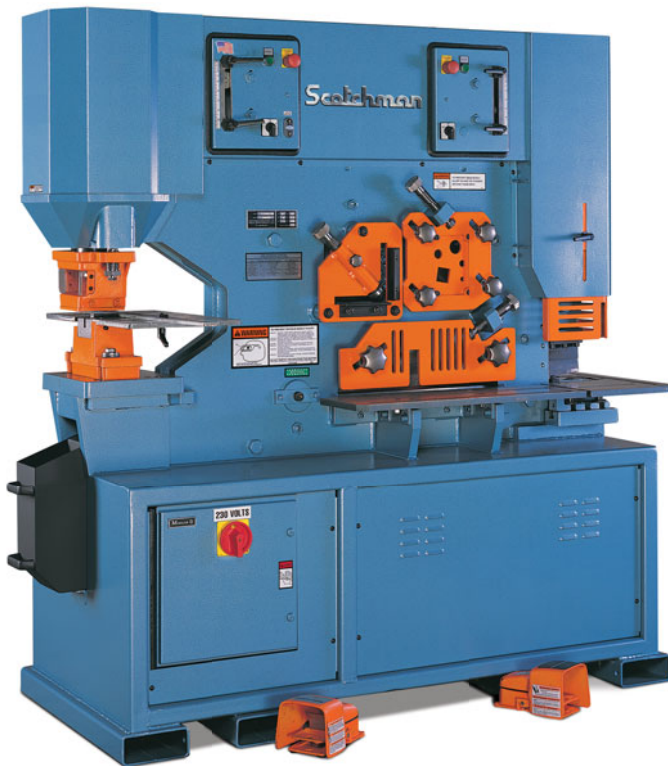

**DUAL
OPERATOR**
5 STATIONS

DO 8514-20M

Capacities and Specifications

Rated On: A36 Mild Steel / 65,000 PSI Tensile

Punching Capacity	85 ton (77 mt) 1-1/16" in 1" (27 mm in 25 mm)
Special Tooling	4" (102 mm) Max. Dia.
Throat Depth	14" (355 mm)
Flat Bar Shear	20" Length, (508 mm) 1" x 14" (25 x 355 mm) 3/4" x 20" (19 x 508 mm)
Angle Shear 90°	6" x 6" x 1/2" (152 x 152 x 12 mm)
Angle Shear 45° (with Bar Shear)	4" x 4" x 1/2" (102 x 102 x 12 mm)
Brake 12"	85 ton (77 mt)
Brake 24"	85 ton (77 mt)
Open End Brake (Notcher Station)	Max. 1/2" x 6" (12 x 152 mm) [Flat or Angle Iron]
Open End Brake (Punch Station)	Max. 1/4" x 5" (6 x 127 mm) [Flat or Angle Iron]
Pipe Notcher Schedule 40	3/4", 1", 1-1/4", 1-1/2", 2"
Rectangle Notcher	2" x 4" x 1/2" (51 x 101 x 12 mm)
90° V-Notcher (Punch Station)	6" x 6" x 5/16" (152 x 152 x 8 mm)
90° V-Notcher (Notcher Station)	3" x 3" x 1/2" (76 x 76 x 12 mm)
Punch Attachment (Notcher Station)	50 ton 1-1/4" in 1/2" (32 mm in 12 mm)
Throat Depth w/ Punch attachment (Notcher Station)	4-7/16" (113 mm)
Channel Shear	2" to 6" (51 mm to 152 mm)
Unistrut Shear	Samples Required
Rod Shear Round (max.)	4 cavities, 1/2", 3/4", 1", 1-1/2" (12 mm, 19 mm, 25 mm, 38 mm)
Rod Shear Square (max.)	1 cavity, 1-1/2" (38 mm)
Square Tube Shear	1/2" to 2" (12 mm to 51 mm) 12 gauge (0.105" / 2.7 mm)
Picket Tool	1/2", 3/4" & 1" (12 mm, 19 mm, 25 mm) 16 gauge (0.06" / 1.5 mm)
Weld Coupon Bender (max.)	2" wide x 3/8" (51 mm x 10 mm)
Offset Die Holder	Max. 40 ton (36 mt)
Strokes per minute in light material	45 spm (1/4" stroke) [Punch Station]
Strokes per minute in heavy material	18 spm (3/4" stroke) [Punch Station]
Hydraulics	3,350/3,800 psi (231/262 bar)
Motor Options (must specify)	10 hp 3 ph (7.46 kW) 208/230/460, 380/575v 10 hp 1 ph (7.46 kW) 220v
Dimensions	L-77-1/2" (197 cm) W-32-1/4" (82 cm) H-74" (188 cm)
Shipping Weight (may vary)	5,504 lbs. (2,497 kg)

IRONWORKERS

STANDARD FEATURES

- Dual operator allows for two operators to work at the same time at full capacity
- 85 ton punch station
- Keyed punch ram for safety
- Punch gauging table with fence and scale
- Die holder complete with 2" die insert
- Punch nut with wrench & stripper
- Adjustable swing-away stripper
- One round punch & die: max. diameter 1-1/4"
- Punch jog control
- Two adjustable electric stroke controls with scale
- Two electric remote foot pedals
- Two 2-stage hydraulic pumps
- Two valves
- Slug-less angle shear
- Rectangle notcher: can be converted to a V-Notcher, 50 ton punch station, or open end brake
- Flat bar shear
- Shear table with miter fence
- Rod shear
- Slug receptacles
- Electrical box supplied with emergency palm button and lock-out tag-out accommodations
- Complies with ANSI B 11.5 safety standards
- Forklift accommodations
- Three-year warranty on parts
- Made in USA



DO 95/140-24M



DUAL OPERATOR

5 STATIONS

IRONWORKERS

STANDARD FEATURES

- Dual operator allows for two operators to work at the same time at full capacity
- 95 ton punch station
- Keyed punch ram for safety
- Punch gauging table with fence and scale
- Die holder complete with 2" die insert
- Punch nut with wrench & stripper
- Adjustable swing-away stripper
- One round punch & die: max. diameter 1-1/4"
- Jog control
- Two adjustable electric stroke controls with scale
- Two electric remote foot pedals
- Two 2-stage hydraulic pumps
- Two valves
- Angle shear
- Rectangle notcher with table, scale and guides
- Flat bar shear with sabre blade
- Shear table with miter fence
- Tool table work area
- Slug receptacles
- Electrical box supplied with emergency palm button and lock-out tag-out accommodations
- Complies with ANSI B 11.5 safety standards
- Forklift accommodations
- Three-year warranty on parts
- Made in USA

Capacities and Specifications

Rated On: A36 Mild Steel / 65,000 PSI Tensile

Punching Capacity	95 ton (86 mt) 1-3/16" in 1" (30 mm in 25 mm)
Special Tooling	4" (102 mm) Max. Dia.
Throat Depth	9" (229 mm)
Flat Bar Shear (sabre blade-std.)	24" Length (610 mm) 1" x 8" (25 x 203 mm) 3/4" x 12" (19 x 305 mm) 1/2" x 16" (12 x 406 mm) 3/8" x 24" (10 x 610 mm)
Angle Shear 90°	6" x 6" x 1/2" (152 x 152 x 12 mm)
Angle Shear 45° w/Tool w/Bar Shear	3" x 3" x 3/8" (76 x 76 x 10 mm) 4" x 4" x 1/2" (102 x 102 x 12 mm)
Brake 12"	80 ton (72.5 mt)
Brake 24"	55 ton (50 mt)
Open End Brake	Max. 1/4" x 5" (6 x 127 mm) [Flat or Angle Iron]
Pipe Notcher Schedule 40	3/4", 1", 1-1/4", 1-1/2", 2"
Rectangle Notcher	3" x 5" x 3/8" (76 x 127 x 10 mm) 3" x 4" x 1/2" (76 x 101 x 12 mm)
90° V-Notcher	6" x 6" x 5/16" (152 x 152 x 8 mm) 3" x 3" x 3/8" (76 x 76 x 10 mm)
Notching in Leg of Channel	6" to 10" (152 mm to 254 mm)
Channel Shear	2" to 6" adj. (51 mm to 152 mm adj.)
Unistrut Shear	Samples Required
Rod Shear Round (max.)	9 Cavity, 1/4" to 1-1/4" (6 mm to 32 mm)
Rod Shear Square (max.)	1 Cavity, 1/4" to 1" (6 mm to 25 mm)
Square Tube Shear	1/2" to 2" (12 mm to 51 mm) 12 gauge (0.105" / 2.7 mm)
Picket Tool	1/2", 3/4" & 1" (12 mm, 19 mm, 25 mm) 16 gauge (0.06" / 1.5 mm)
Weld Coupon Bender (max.)	2" wide x 3/8" (51 mm x 10 mm)
Offset Die Holder	Max. 40 ton (36 mt)
Strokes per minute in light material	38 spm (1/4" stroke) [Punch Station]
Strokes per minute in heavy material	15 spm (3/4" stroke) [Punch Station]
Hydraulics	3,500/3,500 psi (241/241 bar)
Motor Options (must specify)	10 hp 3 ph (7.46 kW) 208/230/460, 380/575v 10 hp 1 ph (7.46 kW) 220v
Dimensions	L-69" (175 cm) W-37-1/2" (95 cm) H-71" (180 cm)
Shipping Weight (may vary)	3,800 lbs. (1,724 kg)



DO 120/200-24M

IRONWORKERS



DUAL OPERATOR
5 STATIONS

STANDARD FEATURES

- Dual operator allows for two operators to work at the same time at full capacity
- 120 ton punch station
- Keyed punch ram for safety
- Punch gauging table with fence and scale
- Die holder complete with 2" die insert
- Punch nut with wrench & stripper
- Adjustable swing-away stripper
- One round punch & die: max. diameter 1-1/4"
- Jog control
- Two electric remote foot pedals
- Two adjustable electric stroke controls with scale
- Two 2-stage hydraulic pumps
- Two valves
- Angle shear
- Rectangle notcher with table, scale and guides
- Flat bar shear with sabre blade
- Shear table with miter fence
- Tool table work area
- Slug receptacles
- Electrical box supplied with emergency palm button and lock-out tag-out accommodations
- Complies with ANSI B 11.5 safety standards
- Forklift accommodations
- Three-year warranty on parts
- Made in USA

Capacities and Specifications

Rated On: A36 Mild Steel / 65,000 PSI Tensile

Punching Capacity	120 ton (108 mt) 1-1/2" in 1" (38 mm in 25 mm)
Special Tooling	4" (102 mm) Max. Dia.
Throat Depth	12" (305 mm)
Flat Bar Shear (sabre blade-std.)	24" Length (610 mm) 1" x 12" (25 x 305 mm) 3/4" x 20" (19 x 508 mm) 1/2" x 24" (12 x 610 mm)
Angle Shear 90°	6" x 6" x 1/2" (152 x 152 x 12 mm)
Angle Shear 45° w/Tool	3" x 3" x 3/8" (76 x 76 x 10 mm)
w/Bar Shear	4" x 4" x 1/2" (102 x 102 x 12 mm)
Brake 12"	75 ton (55 mt)
Brake 24"	55 ton (40 mt)
Open End Brake	Max. 1/4" x 5" (6 x 127 mm) [Flat or Angle Iron]
Pipe Notcher Schedule 40	3/4", 1", 1-1/4", 1-1/2", 2"
Rectangle Notcher	3" x 5-3/4" x 1/2" (76 x 146 x 12 mm)
90° V-Notcher	6" x 6" x 5/16" (152 x 152 x 8 mm) 3" x 3" x 1/2" (76 x 76 x 12 mm)
Notching in Leg of Channel	6" to 10" (152 mm to 254 mm)
Channel Shear	2" to 6" adj. (51 mm to 152 mm adj.)
Unistrut Shear	Samples Required
Rod Shear Round (max.)	9 Cavity, 1/4" to 1-1/4" (6 mm to 32 mm)
Rod Shear Square (max.)	1 Cavity, 1/4" to 1" (6 mm to 25 mm)
Square Tube Shear	1/2" to 2" (12 mm to 51 mm) 12 gauge (0.105" / 2.7 mm)
Picket Tool	1/2", 3/4" & 1" (12 mm, 19 mm, 25 mm) 16 gauge (0.06" / 1.5 mm)
Weld Coupon Bender (max.)	2" wide x 3/8" (51 mm x 10 mm)
Offset Die Holder	Max. 40 ton (36 mt)
Strokes per minute in light material	39 spm (1/4" stroke) [Punch Station]
Strokes per minute in heavy material	15 spm (3/4" stroke) [Punch Station]
Hydraulics	3,500/3,500 psi (241/241 bar)
Motor Options (must specify)	10 hp 3 ph (7.46 kW) 208/230/460, 380/575v 10 hp 1 ph (7.46 kW) 220v
Dimensions	L-83" (211 cm) W-38-1/2" (98 cm) H-76-1/2" (194.5 cm)
Shipping Weight (may vary)	6,204 lbs. (2,814 kg)



135 Ton

IRONWORKERS



**DUAL
OPERATOR**
5 STATIONS

DO 135/220-24M

Capacities and Specifications

Rated On: A36 Mild Steel / 65,000 PSI Tensile

Punching Capacity	135 ton (122 mt) 1-11/16" in 1" (42 mm in 25 mm)
Special Tooling	4" (102 mm) Max. Dia.
Throat Depth	12" (305 mm)
Flat Bar Shear (sabre blade-std.)	24" Length (610 mm) 1" x 12" (25 x 305 mm) 3/4" x 20" (19 x 508 mm) 1/2" x 24" (12 x 610 mm)
Angle Shear 90°	6" x 6" x 1/2" (152 x 152 x 12 mm)
Angle Shear 45° w/Tool w/Bar Shear	3" x 3" x 3/8" (76 x 76 x 10 mm) 4" x 4" x 1/2" (102 x 102 x 12 mm)
Brake 12"	90 ton (81.6 mt)
Brake 24"	70 ton (63.5 mt)
Open End Brake	Max. 1/4" x 5" (6 x 127 mm) [Flat or Angle Iron]
Pipe Notcher Schedule 40	3/4", 1", 1-1/4", 1-1/2", 2"
Rectangle Notcher	3" x 5-3/4" x 1/2" (76 x 146 x 12 mm)
90° V-Notcher	6" x 6" x 5/16" (152 x 152 x 8 mm) 3" x 3" x 1/2" (76 x 76 x 12 mm)
Notching in Leg of Channel	6" to 10" (152 mm to 254 mm)
Channel Shear	2" to 6" adj. (51 mm to 152 mm adj.)
Unistrut Shear	Samples Required
Rod Shear Round (max.)	9 Cavity, 1/4" to 1-1/4" (6 mm to 32 mm)
Rod Shear Square (max.)	1 Cavity, 1/4" to 1" (6 mm to 25 mm)
Square Tube Shear	1/2" to 2" (12 mm to 51 mm) 12 gauge (0.105" / 2.7 mm)
Picket Tool	1/2", 3/4" & 1" (12 mm, 19 mm, 25 mm) 16 gauge (0.06" / 1.5 mm)
Weld Coupon Bender (max.)	2" wide x 3/8" (51 mm x 10 mm)
Offset Die Holder	Max. 40 ton (36 mt)
Strokes per minute in light material	39 spm (1/4" stroke) [Punch Station]
Strokes per minute in heavy material	15 spm (3/4" stroke) [Punch Station]
Hydraulics	3,500/3,500 psi (241/241 bar)
Motor Options (must specify)	10 hp 3 ph (7.46 kW) 208/230/460, 380/575v 10 hp 1 ph (7.46 kW) 220v
Dimensions	L-83" (211 cm) W-38-1/2" (98 cm) H-76-1/2" (194.5 cm)
Shipping Weight (may vary)	6,204 lbs. (2,814 kg)

STANDARD FEATURES

- Dual operator allows for two operators to work at the same time at full capacity
- 135 ton punch station
- Keyed punch ram for safety
- Punch gauging table with fence and scale
- Die Holder complete with a 2" die insert
- Punch nut with wrench & stripper
- Adjustable swing-away stripper
- One round punch & die: max. diameter 1-1/4"
- Jog control
- Two electric remote foot pedals
- Two adjustable electric stroke controls with scale
- Two 2-stage hydraulic pumps
- Two valves
- Angle shear
- Rectangle notcher with table, scale and guides
- Flat bar shear with sabre blade
- Shear table with miter fence
- Tool table work area
- Slug receptacles
- Electrical box supplied with emergency palm button and lock-out tag-out accommodations
- Complies with ANSI B 11.5 safety standards
- Forklift accommodations
- Three-year warranty on parts
- Made in USA



DO 150/240-24M



**DUAL
OPERATOR**
5 STATIONS

IRONWORKERS

STANDARD FEATURES

- Dual operator allows for two operators to work at the same time at full capacity
- 150 ton punch station
- Keyed punch ram for safety
- Punch gauging table with fence and scale
- Die Holder complete with a 2" die insert
- Punch nut with wrench & stripper
- Adjustable swing-away stripper
- One round punch & die: max. diameter 1-1/4"
- Jog control
- Two electric remote foot pedals
- Two adjustable electric stroke controls with scale
- Two 2-stage hydraulic pumps
- Two valves
- Angle shear
- Rectangle notcher with table, scale and guides
- Flat bar shear with sabre blade
- Shear table with miter fence
- Tool table work area
- Slug receptacles
- Electrical box supplied with emergency palm button and lock-out tag-out accommodations
- Complies with ANSI B 11.5 safety standards
- Forklift accommodations
- Three-year warranty on parts
- Made in USA

Capacities and Specifications	
Rated On: A36 Mild Steel / 65,000 PSI Tensile	
Punching Capacity	150 ton (136 mt) 1-7/8" in 1" (47 mm in 25 mm) 2-1/2" in 3/4" (64 mm in 19 mm)
Special Tooling	4" (102 mm) Max. Dia.
Throat Depth	12" (305 mm)
Flat Bar Shear (sabre blade-std.)	24" Length (610 mm) 1" x 14" (25 x 356 mm) 3/4" x 24" (19 x 610 mm)
Angle Shear 90°	6" x 6" x 1/2" (152 x 152 x 12 mm)
Angle Shear 45° w/Tool w/Bar Shear	3" x 3" x 3/8" (76 x 76 x 10 mm) 4" x 4" x 1/2" (102 x 102 x 12 mm)
Brake 12"	90 ton (81.6 mt)
Brake 24"	70 ton (63.5 mt)
Open End Brake	Max. 1/4" x 5" (6 x 127 mm) [Flat or Angle Iron]
Pipe Notcher Schedule 40	3/4", 1", 1-1/4", 1-1/2", 2"
Rectangle Notcher	3" x 5-3/4" x 1/2" (76 x 146 x 12 mm)
90° V-Notcher	6" x 6" x 5/16" (152 x 152 x 8 mm) 3" x 3" x 1/2" (76 x 76 x 12 mm)
Notching in Leg of Channel	6" to 10" (152 mm to 254 mm)
Channel Shear	2" to 6" adj. (51 mm to 152 mm adj.)
Unistrut Shear	Samples Required
Rod Shear Round (max.)	9 Cavity, 1/4" to 1-1/4" (6 mm to 32 mm)
Rod Shear Square (max.)	1 Cavity, 1/4" to 1" (6 mm to 25 mm)
Square Tube Shear	1/2" to 2" (12 mm to 51 mm) 12 gauge (0.105" / 2.7 mm)
Picket Tool	1/2", 3/4" & 1" (12 mm, 19 mm, 25 mm) 16 gauge (0.06" / 1.5 mm)
Weld Coupon Bender (max.)	2" wide x 3/8" (51 mm x 10 mm)
Offset Die Holder	Max. 40 ton (36 mt)
Strokes per minute in light material	44 spm (1/4" stroke) [Punch Station]
Strokes per minute in heavy material	17 spm (3/4" stroke) [Punch Station]
Hydraulics	3,500/3,500 psi (241/241 bar)
Motor Options (must specify)	10 hp 3 ph (7.46 kW) 208/230/460, 380/575v 10 hp 1 ph (7.46 kW) 220v
Dimensions	L-83" (211 cm) W-38-1/2" (98 cm) H-77-1/4" (196.5 cm)
Shipping Weight (may vary)	6,404 lbs. (2,905 kg)



Ironworker *Optional Tooling*

IRONWORKERS

		PF 45	50514-EC	5014-ET	6509	DO70	DO85	FI85	9012	DO95	12012	DO120	DO135	DO150
A	6" Brake	•	•	•										
B	8" Brake	•	•	•										
C	12" Brake	•	•	•	•	•	•	•	•	•	•	•	•	•
D	24" Brake				•	•	•	•	•	•	•	•	•	•
E	Open End Brake	•	•	•	•	•	•	•	•	•	•	•	•	•
F	Pipe Notcher	•	•	•	•	•	•	•	•	•	•	•	•	•
G	Rectangle Notcher	•			•				•		•			
H	90° V-Notcher	•	•	•	•	•	•	•	•	•	•	•	•	•
I	Square Tube Shear	•	•	•	•	•	•	•	•	•	•	•	•	•
J	Rod Shear	•	•	•	•	•			•	•	•	•	•	•
K	Unistrut Shear	•	•	•	•	•	•	•	•	•	•	•	•	•
L	Weld Coupon Bender	•	•	•	•	•	•	•	•	•	•	•	•	•
M	Picket Tool	•	•	•	•	•	•	•	•	•	•	•	•	•
N	Channel Shear				•	•		•	•	•	•	•	•	•
O	Channel Shear Blades						•							
P	6"x 6" Die Holder				•	•	•	•	•	•	•	•	•	•
Q	Offset Die Holder				•	•	•	•	•	•	•	•	•	•
R	Urethane Stripper				•	•	•	•	•	•	•	•	•	•
S	Hydraulic Hold Down				•			•	•		•	•	•	•
T	4" Angle Iron Miter Guide		•	•										
U	6" Angle Iron Miter Guide				•	•			•	•	•	•	•	•
V	Optional Punch for Notcher End						•							
W	Open End Brake for Notcher End						•							
X	30" Material Stop	•												
Y	48" Back Gauge		•	•	•	•	•	•	•	•	•	•	•	•
Z	Brake Table w/ scale & squaring arm 12"	•	•	•	•	•	•	•	•	•	•	•	•	•
Z	Brake Table w/ scale & squaring arm 24"				•	•	•	•	•	•	•	•	•	•
Z	Brake Length Gauge w/ scale 8"	•	•	•										
Z	Brake Length Gauge w/ scale 12"	•	•	•	•	•			•	•	•	•	•	•
Z	Brake Length Gauge w/ scale 24"				•	•			•	•	•	•	•	•
AA	Shear Table w/ Miter Fence		•	•										
BB	Punch Gauging Table w/ Fence & Scale		•	•										
CC	Unequal Leg Blades for Angle Shear				•	•			•	•	•	•	•	•
DD	Multi-Loc Punch Gauging Extension: 36" & 85"				•	•	•	•	•	•	•	•	•	•
EE	Punch Table Extension				•	•	•	•	•	•	•	•	•	•
FF	Tool table extension with punch & die drawer		•	•	•	•			•	•	•	•	•	•
GG	Laser Light (Shear)		•	•	•	•			•	•	•	•	•	•
HH	LED Lights	• (P)	• (P, S, N)	• (P&S)	• (P&S)	• (P&S)	• (P&S)	• (P&S)	• (P&S)	• (P&S)	• (P&S)	• (P&S)	• (P&S)	• (P&S)
II	Jog Control		•	•										
JJ	24" x 5' Conveyor w/ angle iron support		•	•	•	•	•	•	•	•	•	•	•	•

• Punch • Punch & Shear • Punch, Shear & Notch

Ironworker *Optional Tooling*

IRONWORKERS



6" Brake (A)



8" Brake (B)



12" Brake (C)



24" Brake (D)

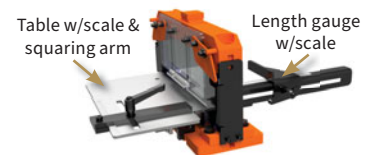

Brake Options (Z)
(sold separately)



Open End Brake (E)



Pipe Notcher (F)



Rectangle Notcher (G)



90° V-Notcher (H)



Square Tube Shear (I)



Rod Shear (J)



Unistrut Shear (K)



Weld Coupon Bender (L)



Picket Tool (M)



Channel Shear (N)



Channel Shear Blades (O)
(DO85 only)



6" x 6" Die Holder (P)



Offset Die Holder (Q)



Urethane Stripper (R)



Hydraulic Hold Down (S)



4" Angle Iron Miter Guide (T)



6" Angle Iron Miter Guide (U)



Optional Punch for Notcher End (V)
(DO85 only)

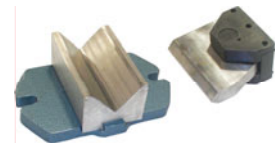

Open End Brake for Notcher End (W)
(DO85 only)



30" Material Stop (X)



48" Back Gauge (Y)



Shear Table w/ Miter Fence (AA)



Punch Gauging Table w/ Fence & Scale (BB)

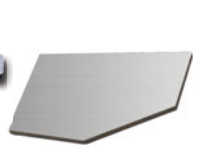

Unequal Leg Blades for Angle Shear (CC)
66°, 70°, 74°, or 80°



Multi-Loc Punch Gauging Extension: 36" & 85" (DD)



Punch Table Extension (EE)



Tool table extension with punch & die drawer (FF)



Laser Light (GG)



LED Lights (HH)



Jog Control (II)



24" x 5' conveyor with angle iron support (JJ)
← (attached to DO 70)
(attached to 5014-ET) →



SOMETIMES, A UNIQUE APPLICATION REQUIRES A CUSTOM-BUILT SOLUTION.

If you need something beyond the standard tooling we offer, our team of engineers is equipped to design and build a tailored solution built to your specifications.

From our plant in Philip, South Dakota, each step of this process from design and development to completion is done in-house.

We thoroughly test each tool to verify performance and ensure value for your investment. With quality manufactured into every tool, we assure that our tools will stand up to the tough demands of your applications.



Examples of Special Applications We've Built Tooling For

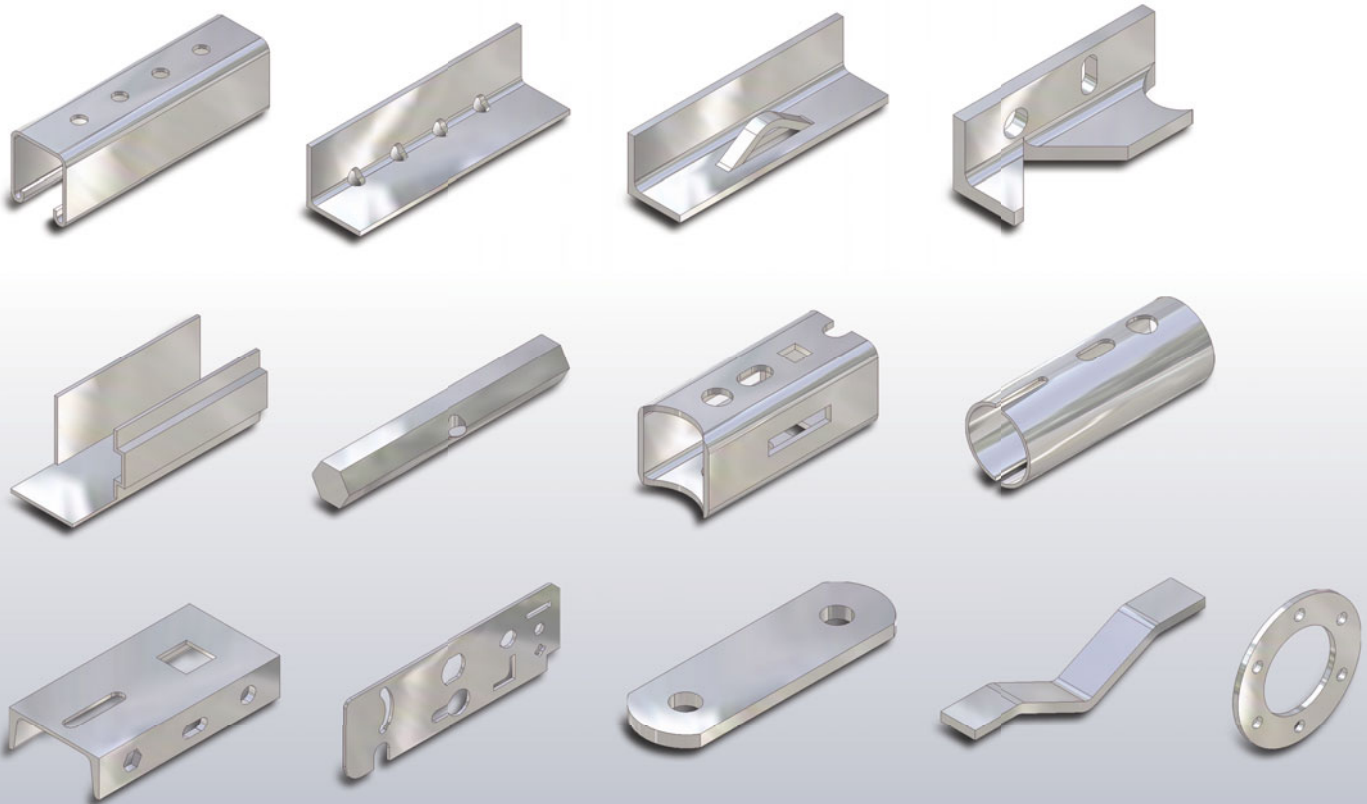

MACHINES
THAT WORK
AS HARD
AS YOU DO.

ScotchmanTM

Metal Fabricating Solutions

Sales partner in México:

ACAT

ACAT Mexicana
Ave. Regio Parque #200 Regio Parque Industrial
Apodaca , Nuevo León, México CP. 66633



acat@acatmexicana.com



TEL. 81 8354 8910



www.acatmexicana.com